



**OHIO TURNPIKE AND  
INFRASTRUCTURE COMMISSION**

**ADDENDUM NO. 2**

**PROJECT NO. 43-18-04**  
**BRIDGE DECK REPLACEMENT AND REHABILITATION**  
**OHIO TURNPIKE OVER WHEELING & LAKE ERIE RAILWAY, M.P. 186.0,**  
**INTERSTATE ROUTE 480 EASTBOUND OVER OHIO TURNPIKE, M.P. 186.8,**  
**PORTAGE COUNTY, OHIO**

**BID OPENING:**  
***EXTENDED TO 2:00 P.M. (EASTERN TIME), JANUARY 25 26, 2018***

**ALL BIDS MUST BE ELECTRONICALLY SUBMITTED THROUGH BID EXPRESS**

**ATTENTION OF BIDDERS IS DIRECTED TO:**

**QUESTIONS AND ANSWERS THROUGH 5:00 PM ON JANUARY 19, 2018**

**-AND-**

**EXTENSION OF THE BID OPENING TO JANUARY 26, 2018**

**-AND-**

**MODIFICATIONS TO THE CONTRACT DOCUMENTS:**

**REVISED PLAN SHEETS NO. 1, 2, 3, 3A, 5, 6, 9, 13, 70, and 103**

**-AND-**

**SPECIAL PROVISION SP525A**

**-AND-**

**REVISION TO THE BID SCHEDULE OF ITEM REF. NO. 12, 13, 14, 43, 44, 45, 61A, 61B,  
61C, 61D, 64A, 64B, 64C, 78, 79, 88, 89, 90, and 91A.**

Issued by the Ohio Turnpike and Infrastructure Commission on January 22, 2018. Issuance authorized by Anthony D. Yacobucci, Chief Engineer, and Mark R. Musson, Director of Contracts Administration.

  
Anthony D. Yacobucci  
Date 1-22-18

  
Mark R. Musson  
Date 1/22/18

**QUESTIONS AND ANSWERS THROUGH 5:00PM ON JANUARY 19, 2018**

**Q#5 Please add bid items for all Work Zone Pavement Markings and remove note C on page 6/113.**

*A#5 Through this Addendum No. 2, the Work Zone Pavement Marking Items have been added to the Contract Documents in the General Summary on Plan Sheet 3 of 113, the Bid Schedule of Estimated Quantities and the Estimated Quantity Worksheet. The revisions incorporate the following:*

<i>Ref. No 64A, Item 614, Work Zone Edge Line, Class I, 6"</i>	<i>5.69 MILE</i>
<i>Ref. No 64B, Item 614, Work Zone Channelizing Line, Class I, 12"</i>	<i>15,211 FOOT</i>
<i>Ref. No 64C, Item 614, Work Zone Dotted Line, Class I</i>	<i>1,815 FOOT</i>

*Furthermore, Note C "Work Zone Pavement Markings" on Plan Sheet 6 of 113 has been revised.*

*Due to the added Pay Items, an additional General Summary Sheet, 3A of 113, has been added to the Contract Documents. This additional Plan Sheet required a revision to the "Index of Sheets" on the Title Sheet, 1 of 113.*

*Furthermore, Sheet 70 of 113 has been revised to correct the location of the Yellow Work Zone Pavement Marking.*

*A new Plan Sheet 3A of 113, as well as revised Plan Sheets 1, 3, 6, and 70 of 113 are provided as part of this Addendum No. 2.*

**Q#6 Please confirm all pavement marking removals both existing and temporary that conflict with the proposed phasing are include in the quantity under reference number 65.**

*A#6 The quantity under Ref. No. 65, Item SP 614C - Removal of Pavement Marking (10.23 Mile) is only for the removal of existing pavement markings on the Ohio Turnpike and does not include the removal of Work Zone Pavement Markings. Through this Addendum No. 2, the Pavement Marking Items have been modified in the Contract Documents in the revised General Summary on Plan Sheet 3 of 113, the Bid Schedule of Estimated Quantities and the Estimated Quantity Worksheet. The revisions provide as follows:*

<i>Ref. No 88, Item 646, Edge Line, 6"</i>	<i><del>4.13</del> 1.78 MILE</i>
<i>Ref. No 89, Item 646, Lane Line, 6"</i>	<i><del>0.85</del> 0.87 MILE</i>
<i>Ref. No 90, Item 646, Channelizing Line, 12"</i>	<i>964 802 FOOT</i>
<i>Ref. No 91A, Item 646, Removal of Pavement Marking</i>	<i>3.15 MILE</i>

*Revised Plan Sheet 3 of 113 is provided as part of this Addendum No. 2.*

**Q#7 Please add bid items for temporary guardrail and end terminal assemblies and remove note D on page 6/113.**

*A#7 Through this Addendum No. 2, the Guardrail and End Terminal Assembly Items have been added to the Contract Documents in the General Summary on Plan Sheet 2 of 113, the Bid Schedule of Estimated Quantities and the Estimated Quantity Worksheet. The revisions provide as follows:*

<i>Ref. No 12, Item 202, Guardrail Removed</i>	<i>675 950</i>	<i>EACH</i>
<i>Ref. No 13, Item 202, Anchor Assembly Removed, Type E</i>	<i>4 2</i>	<i>EACH</i>
<i>Ref. No 14, Item 202, Bridge Terminal Assembly Removed</i>	<i>5 6</i>	<i>EACH</i>
<i>Ref. No 43, Item 606, Guardrail, Type MGS</i>	<i>743 1001</i>	<i>EACH</i>
<i>Ref. No 44, Item 606, Anchor Assembly, MGS Type E</i>	<i>4 2</i>	<i>EACH</i>
<i>Ref. No 45, Item 606, MGS Bridge Terminal Assembly, Type 1</i>	<i>3 4</i>	<i>EACH</i>

*Furthermore, Note D "Work Zone Guardrail Construction" on Sheet 6 of 113 has been revised.*

*Revised Plan Sheets 2 and 6 of 113 are provided as part of this Addendum No. 2.*

**Q#8 Please add bid items for guardrail delineation and remove note E on page 6/113.**

*A#8 Through this Addendum No. 2, the Guardrail Delineation Items have been added to the Contract Documents in the revised General Summary on Plan Sheet 3 of 113, the Bid Schedule of Estimated Quantities and the Estimated Quantity Worksheet. The revisions provide as follows:*

<i>Ref. No 61B, Item 614, Barrier Reflector, Type 1 (1-Way)</i>	<i>3</i>	<i>EACH</i>
<i>Ref. No 61C, Item 614, Barrier Reflector, Type 2 (1-Way)</i>	<i>4</i>	<i>EACH</i>
<i>Ref. No 61D, Item 614, Object Marker, One Way</i>	<i>7</i>	<i>EACH</i>

*Furthermore, Note E "Guardrail Delineation" on Sheet 6 of 113 has been revised.*

*Revised Plan Sheets 3 and 6 of 113 are provided as part of this Addendum No. 2.*

**Q#9 Please add bid items for Work Zone Delineation and remove note I on page 6/113.**

**OHIO TURNPIKE AND INFRASTRUCTURE COMMISSION**  
**PROJECT NO. 43-18-04**  
**ADDENDUM NO. 2**  
**PAGE 4 OF 13**

*A#9 Through this Addendum No. 2, the Work Zone Delineation Items have been added to the Contract Documents in the revised General Summary on Plan Sheet 3 of 113, the Bid Schedule of Estimated Quantities and the Estimated Quantity Worksheet. The revisions provide as follows::*

*Ref. No 61A, Item 614, Work Zone Raised Pavement Marker 1,344 EACH*

*Furthermore, Note I "Work Zone Delineation" on Sheet 6 of 113 has been revised.*

*Revised Plan Sheets 3 and 6 of 113 are provided as part of this Addendum No. 2.*

**Q#32 Please provide "typical section" and "maintenance of traffic plan" drawings for Phase 1 of M.P. 186.8.**

*A#32 Phase 1 Typical Sections and phasing plans to rebuild/widen the shoulders utilized in subsequent phases are not available. The locations of the shoulder reconstruction/widening are shown on the Maintenance of Traffic Phase Plan sheets for the phase(s) that utilize the shoulders for that particular maintenance of traffic pattern, as described in the first paragraph of the Phase 1 M.P. 186.8, Maintenance of Traffic Sequence Note on Sheet 5 of 113.*

*Portable Barrier is required to protect the work areas during the shoulder reconstruction/widening operations per ODOT SCD MT-101.90, Drop-Offs in Work Zones. During the placement of the Portable Barrier, the Contractor is instructed by said note to maintain traffic per ODOT SCD MT-95.30, Closing Right or Left Lane of a Multi-Lane Divided Highway with Drums, SCD MT-98.10 Lane Closures at Entrance Ramps (Frost Rd. interchange to I.R. 480 Eastbound) and SCD MT- 98.20 Lane Closures at Exit Ramp Using Drums (I.R 480 Eastbound exit ramp to Ohio Turnpike Interchange 187). The SCDs detail taper rate, temporary signing, temporary pavement marking/RPM, arrow board, drum/cone and shadow vehicle requirements. Observe that the MT-95.30 lane closures are not permitted to remain in place for more than one day at a time, therefore temporary RPM's are not required (see lane restrictions noted in last column of Sheet 5 of 113).*

*The third paragraph of the Phase 1 M.P. 186 .8 Maintenance of Traffic Sequence Note on Sheet 5 of 113 states that the work zones for the shoulder reconstruction/widening shall be established per "ODOT SCD MT-102.10" Lane Shift on a Multi-Lane Highway Using Portable Barrier. Said note also states that the shoulder work is to be performed "alternately." Therefore, the median and outside work cannot be performed concurrently. SCD MT-102.10 details taper rate, temporary signing, temporary pavement marking/RPM and portable barrier requirements.*

*The Contractor is responsible to determine the sequencing, number and location of the work zones for Phase 1 to best facilitate the Work and meet the Construction*

*Schedule. Sufficient quantity of portable barrier is provided to alternately perform median shoulder reconstruction or outside shoulder reconstruction and widening, including ramp and ramp gore areas (the barrier is to be re-used for each operation). Portable Barrier and temporary pavement marking quantities provided are sufficient to cover the requirements for median and outside shoulder reconstruction. The last sentence of the last paragraph of the Note states that the lane widths be reduced to 11'. The shifted traffic will utilize the existing I.R. 480 Eastbound twenty-four (24) foot wide travel lanes pavement as follows: Two (2) foot wide portable barrier plus two (2) eleven (11) foot temporary lanes for a total of twenty-four (24) feet. Therefore, the Phase 1 traffic will not be shifted onto the opposite shoulder which negates the need for rumble strip mill and fill.*

*The pavement composition for the shoulder widening/reconstruction is detailed in the Item 615 – Pavement for Maintaining Traffic, Class A, As Per Plan Note on Sheet 7 of 113. The corresponding quantity is carried to the General Summary from the Note. The associated grading requirements to perform this work are given in the Earthwork for Maintaining Traffic Note on Sheet 7 of 113. Informational quantities are provided to perform the Work. Payment for the Work associated with the grading is included in the Lump Sum Bid Item, Roads for Maintaining Traffic as stated in the last paragraph of the Item 615 – Pavement for Maintaining Traffic, Class A, As Per Plan Note on Sheet 7 of 113.*

*The ODOT SCD MT- 98.20 Lane Closures at Exit Ramp Using Drums has been added to the Contract Documents, which includes a revision to the “Temporary Traffic Control Notes – MP 186.8” on Sheet 5 of 113 as well as the Title Sheet.*

*Revised Plan Sheets 1 and 5 of 113 are provided as part of this Addendum No. 2.*

**Q#34 Can existing falsework material under MP 186.8 be utilized on the Project, and does the existing falsework material in place meet SP527 specification requirements. Furthermore, upon completion of the Project, who takes ownership of the material?**

*A#34 The existing falsework material may be utilized on the project. When it was placed it was in conformance with SP 527. If the Contractor decides to utilize it, it must be inspected for conformity to, maintained in accordance with, SP 527 for the duration of the Project. If the Contractor elects to use the existing falsework, it shall assume ownership thereof, and shall maintain and remove the falsework in accordance with SP 527 and dispose of it when the Project is completed in accordance with SP 105. If the Contractor does not elect to use the existing falsework, it shall remove this falsework in accordance with SP 527 and dispose of it in accordance with SP 105 before installing new falsework.*

**Q#35** Per plan sheet 60/113 and 61/113, Portable barrier, bridge mounted gets (6) anchors per segment. Please provide anchorage requirements and how to handle potential conflict with existing reinforcing steel in bridge deck.

*A#35 Please reference ODOT Standard Drawing PCB-91, which was included in Addendum No. 1, for anchorage requirements.*

**Q#36** Regarding phased construction joint occurring over beam 'K' on MP186.8 and live traffic being maintained adjacent to beam 'K' during phased construction, has OTIC verified that during the demolition operations, the existing structure will be stable and the adjacent concrete span that will maintain traffic will not deflect significantly to infringe upon the existing 14'-6" vertical clearance? Furthermore, has OTIC verified that the existing concrete deck with 6" width bearing on beam 'k' will be stable with live traffic being maintained and with bridge mounted barrier wall drilled into the existing slab adjacent to beam 'K'?

*A#36 No stability or deflection issues are anticipated due to the location of the phase line.*

**Q#37** Has OTIC looked into Frost Road ongoing construction Project 170066 that will be ongoing through September 2018 and will require ongoing lane closures on 480, and how it will affect MP 186.8 phase construction work? Currently, barrier wall is in place and in conflict with where MP 186.8 temporary pavement widening begins.

*A#37 The Ohio Department of Transportation has agreed to direct the contractor for Project 170066 to implement the following changes to accommodate maintenance of traffic requirements for MP 186.8:*

- Move the portable barrier wall on the LEFT approximately 1ft towards the median from a point starting at the bridge, STA 41+85, extending east to the end of this run.*
- For the barrier wall to the RIGHT, it will be reduced in length and for the portion remaining, will be tapered towards the outside shoulder starting at STA 41+85 to allow for the lane shift. It is proposed to move the start of the OTIC full depth pavement for maintaining traffic to the east, same station that the barrier wall will end, approximate STA 42+25. This will allow the Frost Rd ODOT contractor to maintain critical work space needed for remaining bridge work and not require the barrier wall to be moved more than once.*

*Cooperation between both contractors is expected.*

**Q#38** On page 9 of the plans, under Pavement Repairs, it states that dowels are not required for short term repairs. Will dowels be required for any full depth patch staying in place after the project is complete? If so, dowels would then be required for the full quantity of rigid repairs since the limits of full depth pavement replacement shown in the plans is minimal. Please clarify.

*A#38 The Contractor shall follow ODOT CMS requirements for Item 255, except that placement of dowel bars are not required for short term repairs (pavement areas which will be replaced with full depth pavement as part of the roadway work). Dowels are required in all other areas if specified by the ODOT CMS. Furthermore, the "Pavement Repairs" Note on Sheet 9 of 113 has been revised to further clarify.*

*Revised Plan Sheet 9 of 113 is provided as part of this Addendum No. 2.*

**Q#39** Sheet 104/113, Paving Under Guardrail MP 186.8, I did not see a bid item for this work. The plan note also tells to include grading per 209 Linear Grading, App. Can a bid item for the 209 Linear Grading, APP be added to the proposal? This work may be performed under bid item 35 but it is uncertain.

*A#39 As stated in the "Paving Under Guardrail (M.P. 186.8)" note on Sheet 104 of 133, all work associated with this paving, with the exception of setting guardrail posts, is to be included for payment under Item 441, Asphalt Concrete, Intermediate Course, Type 1, (448), Under Guardrail, As Per Plan. A quantity of 11 Cu. Yd. is carried to the General Summary.*

**Q#40** Sheet 110 and 111/113, depicts the grading limits for the incidental work listed on sheet 7/113 (Earthwork for Maintaining Traffic). Can cross sections, spot grades or calculations be provided for the work listed on sheet 7/113? There are 4,100 cy of excavation and 1,480 cy of embankment is this item.

*A#40 The requirements for this Work are described in the Earthwork for Maintaining Traffic Note on Sheet 7 of 113. Additional information is not available.*

**Q#41** Can one or all of the ramp infields at SR 14 be used as a borrow for the fill needed on the project? Is the material in these areas suitable for 203 Embankment?

**OHIO TURNPIKE AND INFRASTRUCTURE COMMISSION  
PROJECT NO. 43-18-04  
ADDENDUM NO. 2  
PAGE 8 OF 13**

*A#41 The material in the ramp infields at SR 14 cannot be used as borrow for the fill needed on the project.*

**Q#42 On the south side of the turnpike along the tracks is an access path / road. Is this available for use during the construction project?**

*A#42 The Commission does not own or control the parcel of land on which the path/road along the tracks exists. If the contractor desires to use the path/road along the tracks, they will need to obtain an agreement with the owner of that parcel.*

**Q#43 After a field visit, it seems that the existing beam lines 1 – 6 & 13 – 18 on Structure M.P. 186.0 has lead paint on this structural steel. There are no Special Provisions in the specifications for working with Lead Paint, will there be any special requirements when working with existing lead paint?**

*A#43 Special Provision SP525A – Lead Paint Removal – Worker/Environmental Protection and Waste Handling is incorporated into the Contract Documents as part of Addendum No. 2. Cost for remediation shall be considered incidental to the corresponding work items.*

**Q#44 Note 7 on Page 13, states that “All costs associated with the median restoration including, but not limited to, ... unless itemized separately, shall be included in the lump sum bid for Item SP 614, Maintaining Traffic”. The Pavement Replacement for the drainage items (SP 304 Aggregate Base and Item 302 – Bituminous Aggregate Base, PG64-22) both have their own bid items for this work, will these restoration items be paid for under appropriate bid items?**

*A#44 Note 7 on Sheet 13 of 113 is correct. The SP 304, Aggregate Base quantity of 106 CU. YD. in the General Summary represents 35 CU.YD. for outside shoulder reconstruction (see Sheet 10 of 113) plus 71 CU.YD. to be placed beneath the M.P. 186.0 Approach Slabs. Furthermore, Note 5 on Sheet 13 of 113 has been revised to remove the word “ODOT” from the note.*

*Revised Plan Sheet 13 of 113 is provided as part of this Addendum No. 2.*

**Q#45 Please verify the quantity for Ref # 77 – Portable Barrier, 32”, Bridge Mounted, As Per Plan. The current quantity is 400 feet; however, the bridge is 302’ long with barrier for both phases, please revise to 604 feet.**



*A#45 The M.P. 186.8 Item 622, Portable Barrier, 32", Bridge Mounted, As Per Plan is to extend across the approach slabs to beyond the limits of the sleeper slabs. The maximum length required (rounded to even 10' barrier segments) is 400'. See Sheet 71 of 113. The "As Per Plan" designation is explained in the Maintenance of Traffic General Notes on Sheet 6 of 113, under III. H. Portable Barriers first paragraph, second sentence, stating "THE COST FOR TRANSPORTING, INSTALLING, MAINTAINING, REMOVING, STORING AND RE-SETTING THE PORTABLE BARRIER FOR EACH PHASE SHALL BE INCLUDED IN THE ORIGINAL UNIT COST OF SUPPLYING THE BARRIER FOR ITEM 622."*

**Q#46 Please verify how Reference Items # 78 & # 79 will be measured and paid. The Estimated Quantities Sheet is set up to pay the contractor by the unit price per foot; however, SP 622 states that the method of Measurement and Payment shall be paid for as lump sum. Which is correct?**

*A#46 The method of measurement and payment for Item SP622 shall be Lump Sum. The General Summary on Plan Sheet 3 of 113, the Bid Schedule of Estimated Quantities and the Estimated Quantity Worksheet are revised accordingly through this Addendum No. 2. The revisions provide as follows:*

*Ref. No 78, Item SP622, 32" Portable Barrier (Without Glare Screen)  
5,600 FOOT 1 LUMP*

*Ref. No 79, Item SP622, 32" Portable Barrier (With Glare Screen)  
2,270 FOOT 1 LUMP*

*Revised Plan Sheet 3 of 113 is provided as part of this Addendum No. 2.*

**Q#47 Due to the close proximity of MP 186.0 bridge and MP 186.8 bridge, please provide clarification on how to implement necessary ongoing intermediate/short term lane closures Eastbound on OTIC mainline to perform bridge work at MP 186.8 in 2018 construction season. There does not appear to be enough buffer between the long term stationary zones needed to perform work at MP 186.0 and the intermediate/short term lane closures needed to perform work at MP 186.8. Specifically, how can an intermediate/short term right lane and/or right and center lane closure be implemented for MP 186.8 when a long term stationary zone is up during Phase 1 and Phase 2 at MP 186.0?**

*A#47 It is the responsibility of the contractor to determine the construction means and methods necessary to implement the maintenance of traffic requirements.*

**Q#48 Please clarify what is included in Ref No. 66 Roads for maintaining traffic.**

*A#48 Please refer to Maintenance of Traffic notes on Sheet 7 of 113 and ODOT CMS Section 615 for requirements.*

**Q#49 Please clarify and/or provide detail for roadway shoring requirements for phased construction of Item 526 approach slabs on MP 186.8. Additionally, are working drawings required per 501?**

*A#49 Quantities are provided for bridge mounted (anchored) PCB on the approach slab to allow for the phased construction. The PCB shall be anchored with 6 anchors per segment into the approach slab similar to the details shown on Sheets 60 and 61 of 113. Maintaining the integrity of the subgrade adjacent to the phase under construction is the responsibility of the Contractor. Working drawings relating to roadway shoring requirements at MP186.8 are not required.*

**Q#50 Please clarify which reinforcing details are being used to construction item 526 approach slabs.**

*A#50 The MP 186.0 approach slabs shall be constructed per OTIC Standard Drawing AS-1. See the plan view on Sheet 1 and Section A-A on Sheet 2 for reinforcing details. See the Median Parapet Detail on Sheet 2 and the Bar bending diagrams for median parapet reinforcing details. The MP 186.8 approach slabs shall be constructed per ODOT Standard Drawings AS-1-15 and AS-2-15. See the standard drawings and notes on sheet 103 of 113 for applicable details.*

**Q#51 Please clarify whether median parapet wall is to be removed and replaced with Item 526 approach slabs on MP 186.0. If so, please provide clarification and details on how to construct and how to protect opening in median from adjacent contra-flow traffic.**

*A#51 The median parapet is to be removed and replaced with the approach slabs on MP 186.0. The median parapet shall be removed to the vertical construction joint (which splits the median parapet in half), thus preserving the half of the existing median parapet adjacent to active traffic. The median parapet on the approach slab can be constructed similar to the detail shown for the abutment slab median parapets with a construction joint separating the two halves, as shown as Section*

*A-A on Sheet 81 of 113, except the median parapet reinforcing shall be as shown on OTIC Standard Drawing AS-1.*

**Q#52** The current letting date of 1/25/18 for this project is the same date as an ODOT bid letting. There are a number of local, comparable sized projects bidding in the ODOT letting, for which we are preparing a bid. Can the bid date for 42-18-04 be delay until 1/26/18 or 1/30/18?

*A#52 Through this Addendum No.2, the Bid Opening has been extended to 2:00 PM on January 26, 2018.*

**Q#53** Please clarify whether median parapet wall is to be removed and replaced with item 526 approach slabs on MP 186.8. If so, please provide clarification and details on how to construction and how to protect opening in median from adjacent traffic.

*A#53 The existing median parapet at each end of the bridge at MP 186.8 does not bear on the approach slab, therefore, the median parapet along the approach slabs shall not be removed. The new approach slabs shall be constructed up to the toe of the existing median parapet, as shown on revised Sheet 103 of 113 in the detail, "Median Concrete Barrier Detail" which was added as part of Addendum No. 2. Thus, the limits of the approach slab removal correspond with the limits of the approach slab and construction of the new approach slabs will follow Standard Drawing AS-1-15. The median parapet shall be removed and replaced along the tops of the abutment wingwalls. See Sheets 91, 92, and 93 of 113 for clarification of the extents of this removal and replacement at MP 186.8.*

*Revised Plan Sheet 103 of 113 is provided as part of this Addendum No. 2.*

**Q#54** Is clearing and grubbing required to perform the MOT Excavation and Embankment along eastbound 480 STA 55+00 thru 62+50? If so, under which bid item will payment be made?

*A#54 This question will be answered in Addendum No. 3.*

**Q#55** Sheet 7 provides "informational only" quantities for earthwork for maintenance of traffic. Without having cross sections, calculations, grading plan or other required resources, it is impossible to determine the "actual" quantities needed. Can the reference material that was used to determine the "information only" quantities be provided?

A#55 See response to Q#40.

**Q#56 In the general summary, sheet 3/113, Roads for MOT and Pavement for MOT, Class A, APP, these bid items are listed for location M.P. 186.8. It does not appear that these items are necessary for this location. Are these items for location M.P. 186 instead? If so, can the office calcs be provided?**

A#56 Please refer to Maintenance of Traffic notes on Sheet 7 of 113 and ODOT CMS Section 615. Both Items are for MP 186.8, as noted on Sheet 7 of 113. Calculations will not be provided.

**Q#57 Sheet 13/113, shows temporary pavement and pavement repairs. How will payment for the items listed be made?**

A#57 See response to Q#13 (Addendum No. 1) and response to Q#44.

**Q#58 Sheet 13/113, legend note 9, SP 304 Granular Embankment. No bid item for this work is currently in the bid. Please add a bid item for this work be added to the proposal?**

A#58 See response to Q#13 (Addendum No. 1) and Note 7 on Sheet 13 of 113.

### **MODIFIED CONTRACT DOCUMENTS**

With this Addendum No. 2, the Commission substitutes the enclosed material for the following Contract Documents:

Plan Sheets: 1, 2, 3, 3A, 5, 6, 9, 13, 70, and 103 of 113 with additions to the Plan Drawings are called out with a cloud and deletions are marked with a revision triangle as thus:



With this Addendum No. 2, the Commission incorporates the following into the Special Provisions: SP 525A

With this Addendum No. 2, the Commission modifies the Bid Schedule of Items for the following Reference Numbers: 12, 13, 14, 43, 44, 45, 61A, 61B, 61C, 61D, 64A, 64B, 64C, 78, 79, 88, 89, 90, and 91A.

The Commission further modifies the bid opening to 2:00 PM (Eastern) on January 26, 2018.

**Receipt of Addendum No. 2  
Project No. 43-18-04 is hereby acknowledged:**

(Firm Name) \_\_\_\_\_

(Signature) \_\_\_\_\_

(Printed Name) \_\_\_\_\_

(Date) \_\_\_\_\_

**BIDDERS MUST RETURN THE ABOVE ACKNOWLEDGEMENT  
OF RECEIPT OF ADDENDUM NO. 2 WITH THEIR BID.**

## SPECIAL PROVISIONS

**SP 525A**      **LEAD PAINT REMOVAL - WORKER/ENVIRONMENTAL PROTECTION AND WASTE HANDLING**  
*(11-21-12)*

**PART 1.0**      **GENERAL**

**1.01**      **PURPOSE**

- A.      These Special provisions provide the material and execution requirements for protecting the public, Contractor workers, and the environment during the removal of paints containing lead or other toxic metals.
- B.      The Contractor is required to implement and maintain programs and procedures which comply with the requirements of these Special Provisions and all applicable Federal, State and Local OSHA and EPA standards or regulations. The Contractor is cautioned that it must comply with all applicable regulations even if the regulation is not specifically referenced herein. If a State or Local regulation is more restrictive than the requirements of these Special Provisions, the more restrictive requirements prevail.
- C.      Identification of the items below which are of specific interest to the Commission in no way relieves the Contractor of the responsibility to comply with all EPA requirements, nor should it be construed that the Commission, the Federal or Ohio EPA, or City and County regulators are only interested in these items.

**1.02**      **REFERENCE STANDARDS**

- A.      The latest edition of the following regulations, guides, and standards form a part of these Special Provisions.
- B.      Code of Federal Regulations (CFR)
  - 1.      29 CFR 1926, Occupational Safety and Health Regulations for Construction
  - 2.      29 CFR 1926.51, Sanitation
  - 3.      29 CFR 1926.55, Gases, Vapors, Fumes, Dusts, and Mists
  - 4.      29 CFR 1926.62, Lead
  - 5.      29 CFR 1926.450 - 453, Scaffolding
  - 6.      29 CFR 1926.500 – 503, Fall Protection
  - 7.      29 CFR 1926.103, Respiratory Protection
  - 8.      29 CFR 1926.1118, Arsenic
  - 9.      29 CFR 1926.1127, Cadmium
  - 10.     40 CFR 50, National Primary and Secondary Ambient Air Quality Standards
  - 11.     40 CFR 58, Ambient Air Quality Surveillance

## SPECIAL PROVISIONS

12. 40 CFR 60, Appendix A, Method 22, Visual Determination of Fugitive Emissions from Material Sources and Smoke Emissions from Fires
13. 40 CFR 60, Appendix A, Method 9, Visual Determination of the Opacity of Emissions from Stationary Sources
14. 40 CFR 261, Appendix II, Toxicity Characteristic Leaching Procedure
15. 40 CFR 262, Standards Applicable to Generators of Hazardous Waste
16. 40 CFR 263, Standards Applicable to Transporters of Hazardous Waste
17. 40 CFR 264, Standards for Owners and Operators of Hazardous Waste Treatment, Storage, and Disposal Facilities
18. 40 CFR 265, Interim Status Standards for Owners and Operators of Hazardous Waste Treatment, Storage, and Disposal Facilities
19. 40 CFR 265, Subpart C, Preparedness and Prevention
20. 40 CFR 265, Subpart D, Contingency Plan and Emergency Procedures
21. 40 CFR 265.16, Personnel Training
22. 40 CFR 268, Land Disposal Restrictions
23. 40 CFR 302, Designation, Reportable Quantities and Notification
24. 40 CFR 355, Emergency Planning and Notification
25. 49 CFR 171.179, Hazardous Materials Regulations

### C. EPA Methods

1. SW 846, Test Methods for Evaluating Solid Waste - Physical/Chemical Methods
2. Method 3050, Acid Digestion of Sediment, Sludge, and Soils
3. Method 1311, Toxicity Characteristic Leaching Procedure (TCLP)

### D. NIOSH Methods

1. Method 7048, Cadmium
2. Method 7082, Lead
3. Method 7300, Chromium
4. Method 7900, Arsenic

### E. Society for Protective Coatings

1. Guide 6, Guide for Containing Debris Generated During Paint Removal Operations

## SPECIAL PROVISIONS

2. Guide 7, Guide for the Disposal of Lead-Contaminated Surface Preparation Debris
  3. SSPC 93-02, Industrial Lead Paint Removal Handbook, 2nd Edition, Volume I
  4. SSPC 95-06, Project Design, Industrial Lead Paint Removal Handbook, Volume II
- F. American Industrial Hygiene Association
1. Environmental Lead Proficiency Analytical Testing Program (ELPAT)
- G. State of Ohio Regulations
1. Air Quality, Title 37
    - (a) Rule 3704, Ohio Air Pollution Control Regulations
    - (b) Rule 3745, Ohio Ambient Air Quality Regulations
    - (c) Rule 3745-15-07, Air Pollution Nuisances Prohibited
    - (d) Rule 3745-17-08, Restrictions on Emissions of Fugitive Dust
  2. Water Quality, Title 61
    - (a) Rule 6111, Ohio Water Pollution Control Act
  3. Waste Disposal, Title 37
    - (a) Rule 3734, Ohio Solid and Hazardous Waste Disposal Law
    - (b) Rule 3745, Chapters 50-69, Hazardous Waste Management Rules
- H. Equipment Manufacturers' Published Instructions

### 1.03

#### **SUBMITTALS**

- A. The Contractor shall submit the following Plans and programs to the Chief Engineer for review and acceptance. For each submission, the Contractor shall provide information for review by the Chief Engineer in accordance with Article 14 – Submittals, of the General Conditions. The Contractor should anticipate multiple submissions may be required for final acceptance of the Plans and/or programs by the Chief Engineer.
- B. Containment Design
1. Submit the containment design proposed for use during both surface preparation and paint application in accordance with the requirements of these Special Provisions. Include all data, calculations, and assumptions used for the design of the containment and ventilation system; the plan for staging, installing, moving, and removing the containment; methods of attachment that will be used; provisions for dropping the containment in inclement weather; provisions for movement out of navigation lanes;



## SPECIAL PROVISIONS

Plans for maintaining the existing bridge lighting during the Work; and any other information needed to thoroughly describe the containment plan.

2. If the containment system will impose live or dead loads on the structure (e.g. suspended platforms), provide a structural analysis by a registered Professional Engineer. Should a lift truck or truck mounted platform be utilized, provide calculations to demonstrate the platforms ability to support any intended load.
3. Include evidence of the education, training, experience, and qualifications of the State of Ohio registered Structural and Mechanical Professional Engineers who will be evaluating and approving the containment system, and for the State of Ohio registered structural Professional Engineer with experience in structural design and safety who will be analyzing the bridge structure.
4. Provide all drawings, data, calculations, and assumptions used for the design of the containment and analysis of loads to the Chief Engineer in quadruplet.
5. Confirm that appropriate notification and coordination with other organizations or agencies such as the Coast Guard and Railroad have been accomplished with regard to right of ways, containment clearances, and other Project restrictions.

### C. Environmental Compliance Plan

Submit an Environmental Compliance Plan, which establishes programs for the monitoring activities that are the responsibility of the Contractor, and includes provisions for complying with the results of any monitoring and analysis conducted by the Commission. Include the following programs in the Plan:

#### 1. Assessments of Visible Emissions and Releases

A written program for the observation of visible emissions during Project activities, and inspections for releases or spills of dust and debris that become deposited on surrounding equipment and property. Include the frequency of observations (minimum three (3) times daily) and inspections that will be made, areas or Work activities that will be observed, and methods of observation and inspection that will be utilized. Include a statement that if emissions above the acceptance criteria are observed that Work will be halted immediately and corrective action taken. Include the name(s) and qualifications of the personnel conducting the observations and inspections. Confirm that visible emission observations will be documented and made available for review by the Chief Engineer. Provide statement that daily (or more frequent) clean up will be performed for any material released outside of the Work area.

#### 2. Final Cleaning/Clearance Evaluations

A written program identifying the procedures and methods that will be used to conduct final Project clean up, and final cleanliness inspections and evaluations. Include confirmation that a final clearance report will be

## SPECIAL PROVISIONS

completed and submitted to the Chief Engineer within ten (10) days of demobilization.

4. Compliance With Monitoring Conducted by the Commission

Include statements in the Plan that Work activities will immediately cease and corrective action will be implemented if the results of any monitoring and analysis that may be undertaken by the Commission show that violations of emissions criteria are occurring.

5. Remediation of Ground (Soil), Water, and Sediment

Include provisions in the Plan that in the event post-Project sampling and analysis show unacceptable results, the Contractor will undertake the necessary clean up or remediation of the ground (soil), water, and/or sediment, when directed by the Chief Engineer, at no additional cost to the Commission. Clean-up of the media to pre-Project levels is required.

D. Worker Lead (Toxic Metal) Health and Safety Compliance Program

1. Compliance Program

A written, Project-specific compliance program, prepared under the direction of, and signed and sealed by a Certified Industrial Hygienist (CIH), for the protection of Contractor workers from lead in accordance with 29 CFR 1926.62 and other toxic metals in the paint. Verify that any Subcontractors working for the Contractor are included in the program or in a separate program, which meets the requirements of this Item. If Subcontractors are operating under a separate program, include the program with the submittals. Include specific details regarding the activities which will result in lead exposures, engineering and Work practice controls, training, personal protective equipment including respiratory protection, hygiene facilities, biological and Worker exposure monitoring for lead and other toxic metals.

2. Personnel Qualifications

Provide the name, experience, and qualifications of both the CIH who will be overseeing the development of the compliance program, and the competent person who will be making routine inspections of Project activities to ensure compliance with the program. Include evidence of training (i.e. C-3) and experience of the competent person as required by the SSPC PCCP program for QP-2 certified Contractors. Confirm that regular inspections will be performed by the competent person and identify the frequency.

3. Outside Laundry

Provide the name, address, and qualifications of the launderer, if one will be used, for the cleaning of reusable clothing. Provide a letter from the laundry indicating that it is permitted to handle clothing contaminated with lead and/or the other toxic metals of concern.

## SPECIAL PROVISIONS

### 4. Personal Protective Equipment for Commission Use

Acknowledge that all protective clothing and equipment, laundering or disposal, fit testing as needed, and hygiene facilities will be provided for up to two (2) designees of the Chief Engineer each day.

## E. Waste Handling, Storage, and Disposal Plan

### 1. Waste Handling and Disposal Plan

Provide a written program that addresses the proper handling and disposal for all waste. Include the procedures that will be followed for the collection of representative samples of the waste for testing; the testing and analysis procedures that will be used; the procedures for the site handling, storage, and packaging of the waste; and contingency Plans in the event of a spill. Include procedures that will be followed to assure that all reusable items such as equipment, containment materials, and scaffolding are properly cleaned prior to removal from the site.

### 2. Transporter Information

Provide the names, addresses, license or permit numbers, and qualifications of the proposed haulers of hazardous waste, non-hazardous waste, and wastewater.

### 3. Hazardous Waste Disposal Information

Provide a letter from a legally permitted hazardous waste disposal facility, stating that the facility has agreed to accept the waste; is authorized to accept the waste under the laws of the state of residence; has the required capability to treat and dispose of the materials; and will provide or assure the ultimate disposal method indicated on the Uniform Hazardous Waste Manifest. Provide the Chief Engineer with the original letter signed by a legally authorized representative of the facility.

### 4. Non-Hazardous and Wastewater Disposal Information

Submit the name and address of the facilities that will accept the non-hazardous waste and wastewater generated by the Contractor. Provide the Chief Engineer with documentation stating that the levels of lead or other toxic metals remaining in the water are acceptable to the facility.

## F. Laboratory/Monitoring Firm Qualifications

1. Provide the name, address, experience, and qualifications of the laboratory and/or firm that will be used for the testing and analysis required in these Special Provisions, including but not limited to worker and area exposure monitoring, waste and wastewater sampling and analysis.

2. Verify that the analytical laboratory used for sample analysis is accredited for metals analysis by the American Industrial Hygiene Association (AIHA) analysis and/or must have successfully participated (previous twelve (12) months at a minimum) in the AIHA ELPAT program.

## SPECIAL PROVISIONS

### G. Commission Review

1. Do not construe Chief Engineer acceptance of Contractor submittals to imply approval of any particular method or sequence for conducting the Work, or for addressing health and safety. Acceptance of the programs does not relieve the Contractor from the responsibility to conduct the Work in strict accordance with the requirements of these Special Provisions, or to adequately protect the health and safety of all workers involved in the Project including any members of the public who may be affected by the Project.
2. The Contractor remains solely responsible for the adequacy and completeness of the programs and Work practices and adherence to them.

### **1.04 CONTRACTOR QUALIFICATIONS**

Society for Protective Coatings QP-2 Certification. Per SP 120, the certification must be in effect at the time of bid and must remain in effect throughout the duration of the Project. Provide a competent person for the Project who meets the QP-2 requirements for a competent person.

## **PART 2.0 PRODUCTS**

### **2.01 CONTAINMENT MATERIALS**

- A. Supply all materials needed to contain Project debris in accordance with the requirements of these Special Provisions. This includes ground covers, rigging, scaffolding, planking, and containment materials.
- B. Use materials that are free of loose dust and debris when brought onto each bridge site, and upon removal.

### **2.02 MONITORING AND TESTING EQUIPMENT**

- A. Supply the instrumentation needed for the monitoring of worker and area exposures, and waste sampling, including all equipment needed for its operation (e.g., generators, batteries, power cords, fuel, etc.)

### **2.03 PERSONAL PROTECTIVE EQUIPMENT AND HYGIENE FACILITIES**

- A. Provide all personal protective equipment (PPE) and hygiene facilities needed for the Project in accordance with the requirements of these Special Provisions. Provide all necessary protective equipment and clothing for use by up to two (2) designees of the Chief Engineer each day, including proper cleaning and disposal.
- B. Use PPE and hygiene facilities that are free of lead or other toxic materials when brought onto each bridge site, and that are clean upon removal.

## SPECIAL PROVISIONS

### **2.04 WASTE CONTAINERS**

A. Hazardous Waste

Provide ODOT-approved containers of the appropriate size and type for the hazardous waste generated on the Project. Use containers that are resistant to rust and corrosion (painted, if constructed of steel), that have tight fitting lids or covers, and which are water resistant and leak proof.

B. Municipal/Construction Waste

Provide all containers for non-hazardous municipal/construction waste. Use containers that are free of loose debris when brought on-site.

C. Spent Solvents

Provide appropriate containers for spent solvents and paint debris.

### **2.05 CONTRACTORS EQUIPMENT AND RECYCLED STEEL GRIT**

A. Provide dust collection and abrasive recycling equipment that are free of loose debris upon arrival to the job site. Dust entrained in the filters from previous use is acceptable.

B. Recyclable abrasives from prior use are permitted provided the abrasive has been cleaned of paint debris and other foreign matter before arrival on site. Abrasive that has not been previously cleaned will be rejected and must be immediately removed from the Project site.

C. Prior to demobilization, dispose of the used recyclable abrasive as hazardous waste, or clean it to remove paint debris and other foreign materials. Remove all loose debris from the equipment and filtration systems.

## **PART 3.0 EXECUTION**

### **3.01 WORKER PROTECTION**

A. General

1. Conduct the Work in strict accordance with Federal, state, and local regulations governing worker protection. All worker protection requirements apply to Contractor and Subcontractor personnel.

2. Identification of the items below which are of specific interest to the Commission in no way relieves the Contractor of the responsibility to comply with all OSHA requirements, nor should it be construed that the Commission or OSHA are only interested in these items.

3. The requirements identified below are based on the OSHA Lead in Construction Standard, 29 CFR 1926.62, but the Contractor must protect the employees from exposure to any of the other toxic metals which may be present in the paint in addition to lead.

## SPECIAL PROVISIONS

### B. Compliance Program

1. Implement a written Compliance Program prepared under the direction of, and signed and sealed by a CIH to establish and implement practices and procedures for protecting the health of those employees exposed to lead and other toxic metals contained in the paint. This program is in addition to other OSHA hazard communication and safety and health requirements of the Project. Revise and update the program at least every six (6) months.
2. Establish methods for complying with these Special Provisions and any OSHA standards published for the toxic metals present in the paint (e.g., 29 CFR 1926.62 for lead and 29 CFR 1926.1127 for cadmium.) When toxic metals are present in the paint for which OSHA has not developed a comprehensive health and safety standard, include statements that the workers will not be exposed above the PEL established for the metal as identified in 29 CFR 1926.55.
3. Identify the methods of compliance that will be used to reduce worker exposures to lead and other toxic metals. Rely on respiratory protection only after feasible engineering and Work practice controls have been first implemented to reduce airborne exposures.
4. Confirm that regular inspections of the Work area will be made by a competent person.

### C. Exposure Monitoring

1. Collect representative personal air samples for each task at the beginning of the paint removal Work (at Project start-up) to determine employee exposures to lead and other toxic metals that might be present in the coating. Tasks resulting in potential exposure to toxic metals include, but are not limited to, paint removal activities, cleanup, and debris handling operations. Collect full shift (at least seven (7) hours) air samples for each job classification in each exposure area. Provide the Chief Engineer with the results of the analysis within the same five (5) day notification period required for the employees, but no later than ten (10) days after sampling.
2. When lead is present, protect workers during the initial monitoring to the anticipated exposure levels as dictated by 29 CFR 1926.62 and as specified below. A few activities in addition to those dictated by OSHA are included below. Use the same level of protection when other toxic metals are found in the coating, unless OSHA has developed a comprehensive health and safety standard for that metal. In those cases, implement the protection requirements of the standard for that metal.
  - (a) Assume an exposure of at least 500  $\mu\text{g}/\text{m}^3$ : Manual demolition of structures containing lead-containing coatings or paint (e.g., dry wall), manual scraping, manual sanding, and power tool cleaning with dust collection systems. Although not identified in 29 CFR 1926.62, include chemical stripping and the operation of abrasive grit recovery equipment in this category.

## SPECIAL PROVISIONS

- (b) Assume an exposure of at least 2,500  $\mu\text{g}/\text{m}^3$ : Conducting the following activities where lead-containing coatings or paint are present: rivet busting, power tool cleaning without dust collection systems, cleanup activities where dry expendable abrasives are used, and the movement and removal of abrasive blasting enclosures. Although not identified in 29 CFR 1926.62, include water jetting and wet abrasive blasting removal of paint in this category.
  - (c) Assume an exposure of more than 2,500  $\mu\text{g}/\text{m}^3$ : Activities involving lead containing coatings or paint on structures disturbed by abrasive blasting, welding, cutting, and torch burning.
- 3. Protection for any of the above activities requires compliance with the necessary respiratory protection, personal protective clothing and equipment, change areas and washing facilities, blood lead and zinc protoporphyrin monitoring, and employee training. Modify the protection measures as necessary, after the exposure results are received.
  - 4. Collect and analyze all air samples for lead, cadmium, chromium and arsenic according to the appropriate NIOSH method for the metals of concern (e.g., Method 7082 for lead.) Use only AIHA accredited laboratories as submitted to and accepted by the Chief Engineer.
  - 5. Conduct periodic monitoring and provide employee notifications in strict accordance with the applicable OSHA standard for the metal of concern (e.g., 29 CFR 1926.62 for lead.) If a standard does not exist, conduct the monitoring and employee notification based on the requirements of OSHA 29 CFR 1926.62. Provide the Chief Engineer with the results of any monitoring within the same five (5) day notification period required for the employee, but not later than ten (10) days after sampling.

### D. Action Level

- 1. The Action Level for lead is thirty (30)  $\mu\text{g}/\text{m}^3$  as an eight (8) hour Time Weighted Average (TWA), the Action Level for cadmium is 2.5  $\mu\text{g}/\text{m}^3$  as an eight (8) hour TWA, and the Action Level for inorganic arsenic is five (5)  $\mu\text{g}/\text{m}^3$  as an eight (8) hour TWA. For other metals that are found in the coating, and for which no Action Level exists, establish the Action Level at 1/2 of the PEL. If a PEL does not exist, establish the Action Level at 1/2 of the Threshold Limit Value (TLV) found in Appendix A of 29 CFR 1926.55 (e.g., if the TLV is five (5)  $\mu\text{g}/\text{m}^3$ , establish the Action Level at 2.5 $\mu\text{g}/\text{m}^3$ .)
- 2. In addition to the initial protection provided, invoke the following protective measures when the airborne exposure to a toxic metal found in the coating exceeds the Action Level:
  - (a) Exposure Monitoring
  - (b) Housekeeping
  - (c) Employee Medical Surveillance and Medical Removal Protection
  - (d) Employee Information and Training

## SPECIAL PROVISIONS

(e) Signs and Regulated Areas

(f) Recordkeeping

### E. Permissible Exposure Limit (PEL)

1. The PEL for airborne lead exposure is fifty (50)  $\mu\text{g}/\text{m}^3$  as an eight (8) hour TWA. The PEL for cadmium is five (5)  $\mu\text{g}/\text{m}^3$  as an eight (8) hour TWA, and for inorganic arsenic is ten (10)  $\mu\text{g}/\text{m}^3$  as an eight (8) hour TWA. The TLVs for other metals can be found in 29 CFR 1926.55.
2. In the event that extended Work shifts are allowed, use the following formula to adjust the PEL: Adjusted PEL = Eight (8) hr. PEL x (eight (8) ÷ hours worked in a day.)
3. In addition to complying with the requirements identified when exceeding the Action Level, invoke the following protective measures when the airborne exposure to a toxic metal found in the coating exceeds the PEL:
  - (a) Compliance Program
  - (b) Respiratory Protection
  - (c) Protective Clothing and Equipment
  - (d) Hygiene Facilities and Practices

### F. Respiratory Protection

1. After feasible engineering controls and Work practices have been implemented, use respiratory protection if necessary to maintain employees' exposures to lead and other toxic metals below the PEL. Require the use of respirators for all employees, inspectors, observers, or other personnel who enter areas where airborne exposures exceed or are expected to exceed the PEL, or when entering regulated areas.
2. Provide respiratory protection as required for up to two (2) designees of the Chief Engineer each day.
3. Develop a written Respiratory Protection Program in compliance with 29 CFR 1926.103. When lead is present, include the provisions of 29 CFR 1926.62. When cadmium and arsenic are present, include 29 CFR 1926.1127 and .1118, respectively. Address the selection, use, maintenance and inspection of respirators, and qualifications for respirator use including medical clearance to wear respiratory protection and evidence of fit testing.
4. Treat used respirator cartridges as waste and dispose of in accordance with the requirements of these Special Provisions.

### G. Protective Clothing and Equipment

1. Provide protective clothing and equipment and ensure they are worn by all employees whose exposures exceed the PEL, or employees who enter regulated areas. Provide all required protective clothing and



## SPECIAL PROVISIONS

equipment for use by up to two (2) designees of the Chief Engineer each day.

2. Do not allow workers to wear street clothing beneath protective clothing in any areas where exposure to toxic metals exceeds the PEL, or when entering regulated areas.
3. Clean or replace the protective clothing as required by the appropriate OSHA standard for the toxic metal that is present. In the case of lead, clean or replace the clothing weekly if the airborne exposure levels are less than  $200 \mu\text{g}/\text{m}^3$  as an eight (8) hour TWA, or daily if the exposure levels are greater than or equal to  $200 \mu\text{g}/\text{m}^3$ .
4. Use vacuums equipped with HEPA filters for personal decontamination when leaving the Work area. Do not remove or clean the clothing by any means, which reintroduces the toxic metals into the ambient air such as brushing, shaking, or blowing.
5. Store the used clothing in sealed containers.
  - (a) If the clothing is to be laundered label the containers with the following: "CAUTION: CLOTHING CONTAMINATED WITH LEAD. DO NOT REMOVE DUST BY BLOWING OR SHAKING. DISPOSE OF LEAD CONTAMINATED WASH WATER IN ACCORDANCE WITH APPLICABLE LOCAL, STATE OR FEDERAL REGULATIONS."
  - (b) If the clothing is disposable, label the containers as lead contaminated clothing. Apply hazardous waste labels as appropriate after testing.
6. If an outside laundry is used for the cleaning of the clothing, provide a letter from the laundry in accordance with these Special Provisions.
7. If the clothing is washed on site, provide containers for the collection, retention, and testing of the water after filtration in accordance with these Special Provisions.
8. Assure that employees do not leave the Project site wearing any clothing that was worn while performing activities where exposures exceeded the PELs, or while working within regulated areas.

### H. Housekeeping

1. Clean accumulations of dust or debris containing lead or other toxic metals daily, at a minimum. Clean more frequently if visible accumulations are observed that could be carried outside of the regulated area. Containerize the debris for proper disposal.
2. Conduct all cleaning with HEPA vacuums and deposit all dust and debris into sealed containers. The use of compressed air for housekeeping purposes is strictly prohibited unless used in conjunction with a ventilation system capable of capturing the resulting airborne particulate.

## SPECIAL PROVISIONS

### I. Personal Hygiene Facilities and Equipment

1. Provide clean lavatory and hand washing facilities in accordance with OSHA sanitation standard 29 CFR 1926.51. Provide showers when exposures exceed the PEL. Confirm that all employees whose exposures exceed the PEL shower prior to leaving the Project site.
2. Filter and containerize all water and make arrangements for proper disposal in accordance with these Special Provisions.
3. Prohibit eating, drinking, smoking, chewing of food or tobacco products, or the application of cosmetics in any area where the exposure to toxic metals exceeds the PELs or within regulated areas, and confirm that workers thoroughly wash hands and face prior to undertaking any of these activities.
4. Provide clean lunch and break areas for use by all employees, and maintain airborne concentrations in these areas below the Action Levels.
5. Provide clean change area(s) for employees whose exposures exceed the PELs. Equip the change area(s) with separate storage facilities for street clothing that are adequately segregated to prevent cross-contamination from Work clothing.

### J. Medical Surveillance and Medical Removal Protection

1. Provide all employees with initial and periodic blood and zinc protoporphyrin (ZPP) sampling and analysis, and medical surveillance as required by published OSHA health and safety standards that may exist for the metal of concern such as 1926.62 for lead and 1926.1127 for cadmium. In the case of lead, this requires testing at a minimum of once every two (2) months for the first six (6) months of exposure, and at six (6) month intervals thereafter. Verify that the blood analysis is conducted by laboratories approved by OSHA.
2. Do not use workers with initial blood lead tests of forty (40) µg/dl or above for any Work activities involving exposure to lead above the Action Level. Conduct exit blood tests for each worker upon completion of its Project activities, even if this occurs prior to the completion of the Contractor's Work on the Project.
3. Provide for the temporary removal of employees from exposures above the Action Level for the metal of concern when the blood analysis indicates that unacceptable results are occurring (e.g., fifty (50) µg/dl or above in the case of blood lead.) Protect employees' benefits during any period of medical removal and conduct all tests required by the appropriate OSHA standards during the removal period.
4. Provide all physical examinations as required by the appropriate OSHA standards for metal(s) of concern and verify that all examinations are performed by or under the direct supervision of the licensed physician.
5. Provide all exam information and test results to the employees in writing within five (5) days of receipt.

### K. Employee Information and Training

## SPECIAL PROVISIONS

1. Provide initial and annual refresher training for all employees who are exposed to toxic metals above the respective Action Levels on any one (1) day in a twelve (12) month period. Include all of the elements of training that are required by the appropriate OSHA standard. If a standard for the metal does not exist, use the training requirements of 29 CFR 1926.62 as the basis of the training program highlighting the differences as appropriate for the other metals of concern.
2. When other Contractors or employers are present at the site, notify them of the nature of the lead exposure Work, the need to remain out of exposure areas, the warning signs and labeling system in effect, and the potential need for them to take measures to protect their employees, in accordance with the applicable OSHA regulations.

### L. Signs and Regulated Areas

1. Establish regulated areas around activities where airborne levels of toxic metals exceed the respective Action Levels.
2. Post caution signs around the Work area. If a regulation does not exist for the metal of concern, use the legend for the CAUTION sign as found in 29 CFR 1926.62 as the basis, inserting the name(s) of the other toxic metals:

**WARNING  
LEAD WORK AREA  
POISON  
NO SMOKING OR EATING**

3. Verify that all workers who enter the regulated area have had the proper training, blood analysis and medical examinations, and are wearing the required protective clothing and respiratory protection. Prohibit eating, drinking, smoking, and chewing of food or tobacco products within the regulated area(s.)

### M. Recordkeeping

1. Retain all records related to training, medical examinations, blood analysis, exposure monitoring, respirator fit testing and medical clearance, inspections by a competent person, and other related Project documentation of file at the Project site.
2. Make all records available for review by the Chief Engineer upon request.
3. Retain all records for the duration of employment plus thirty (30) years.

## **3.02 ESTABLISHMENT OF REGULATED AREAS**

- A. Establish zones (regulated areas) around areas or activities that might generate airborne emissions of lead, cadmium, chromium, or other toxic metal in excess of the Action level (e.g., paint removal and clean-up locations, dust collector staging areas, waste storage areas, etc.) Use ropes, ribbons, tape, or other visible means to define the areas together with appropriate signage, and prohibit entrance into the regulated areas by unprotected or untrained personnel.

## SPECIAL PROVISIONS

- B. Conduct sampling for lead and any other toxic metals that may be present in the coating, according to the appropriate NIOSH method.
  - 1. Conduct the sampling upon commencement of the paint removal activities (at Project-start-up) at the boundary of the regulated area. Collect the samples throughout an entire Work shift.
  - 2. Verify that the samples are analyzed by the laboratory, submitted to and accepted by the Chief Engineer. Provide the test results to the Chief Engineer **in writing** within five (5) days of sampling.
- C. Unless otherwise directed by the Chief Engineer, until test results are available to establish the perimeter of the regulated area, initially establish the boundary a minimum of fifteen feet (15') away from any equipment or operations that might generate airborne emissions of toxic metals.
  - 1. If the monitoring confirms that Project emissions at the established boundary do not exceed the Action Level as an eight (8) hour TWA, establish the boundary at that location and discontinue monitoring.
  - 2. If the monitoring shows that the emissions exceed the Action Level, modify and improve Work practices and containment to provide better controls over the emissions, or reestablish the boundary at a different location if allowed by the Chief Engineer. Repeat the monitoring in either case.
- D. After the boundaries have been established through instrument monitoring, additional monitoring is not required unless directed by the Chief Engineer, if suspect visible emissions occur, or when there are changes to the Work practices or equipment being used within the regulated areas.

### 3.03

#### **AIR QUALITY - VISIBLE EMISSIONS AND HIGH VOLUME AMBIENT AIR MONITORING**

- A. Assessment of Visible Emissions and Releases
  - 1. General Visible Emissions Monitoring Requirements
    - (a) Conduct visible emissions assessments in accordance with 40 CFR 60, Appendix A, Method 22. These assessments are based on total visible emissions regardless of the opacity of the emission.
    - (b) In addition to assessments of airborne emissions, conduct visual inspections for releases or spills of dust and debris that have become deposited on surrounding property, structures, equipment or vehicles, and bodies of water.
    - (c) In the event there are unique State, City, or County regulations regarding visible emissions, they are considered to be in addition to, but not in lieu of, the requirements of this Item.

## SPECIAL PROVISIONS

### 2. Acceptance Criteria for Visible Emissions Assessments

- (a) Random visible emissions from Project activities are restricted to an SSPC Level 1 (no greater than one (1)% of the workday) in accordance with SSPC Guide 6. Conduct visible emission assessments in accordance with 40 CFR 60, Appendix A, Method 22.
- (b) Visible emissions in excess of the above criteria are cause for immediate Project shut down until the cause of the emissions is corrected.
- (c) Note that violations of any high volume ambient air monitoring that might be conducted by the Commission are cause for immediate Project shut down and the initiation of corrective action, even if the visible emissions results are acceptable.

### 3. Frequency and Location of Emissions Assessments and Inspections

- (a) Conduct the visible emissions assessments to account for all locations where emissions of lead dust might be generated, including but not limited to, the containment, dust collection and abrasive recovery equipment, and waste containerizing areas.
- (b) Casual observations and corrections of visible emissions and releases of dust or debris are an ongoing daily requirement, but conduct and document the results of the specialized assessments and inspections as described in these Special Provisions at least three times each day.
- (c) Guidance on visible emissions assessments can be found in Method PD/Lead A4 of SSPC publication 95-06, Project Design.

### 4. Reporting of Visible Emissions

- (a) Report the results of the daily assessments in a logbook or other report form and make available for review by the Chief Engineer upon request.
- (b) Document all cases where Work has been halted due to unacceptable visible emissions or releases of material, the cleanup activities invoked, and the corrective action taken to avoid a reoccurrence.

### B. High Volume Ambient Air Monitoring

- 1. The Commission may undertake high volume ambient air monitoring during paint removal and clean-up activities to confirm that emissions do not exceed the EPA National Primary and Secondary Ambient Air Quality Standards (NAAQS), or specific County or City regulations.
- 2. The Contractor will be advised if such monitoring will be performed.
- 3. The Contractor will be required to comply with the acceptance criteria established in City or County regulations when available. If there are no

## SPECIAL PROVISIONS

local regulations governing high volume ambient air monitoring, the criteria established in 40 CFR 50 will be invoked as summarized below:

(a) TSP-Lead (Total Suspended Particulate-Lead) - Do not exceed  $1.5 \mu\text{g}/\text{m}^3$  averaged over a ninety (90) day period or  $13.5 \mu\text{g}/\text{m}^3$  over an average workday.

4. If monitoring is conducted and the above criteria are violated, immediately stop Work and make changes to the containment and/or Work practices to achieve compliance. Note that exceedances may also result in City or County violations.

### **3.04 RESTRICTIONS ON EMISSIONS TO GROUND (SOIL), WATER, AND SEDIMENT**

- A. Conduct all activities so that releases to the soil, water, sediment, or storm sewers do not occur.
- B. The release of particulate or debris beyond the contained or protected areas is cause for immediate Project shut down until the cause of the emissions is corrected and clean-up of all visible deposits is completed.
- C. Clean up visible deposits of debris on the unprotected ground, on the soil, on or in the water or sediment, around storm sewers or drains, or in areas where rain water could carry the debris into storm sewers or drains. Take the appropriate corrective actions.
- D. The Chief Engineer may conduct laboratory testing and analysis of soil, water, and/or sediment. The Contractor will be advised if such testing and analysis will be performed. The ground (soil), water, and sediment will be considered to have been impacted by Project activities based on the laboratory analysis as described below:
  - 1. Visible paint chips or debris on the ground, water, or sediment are not permitted and must be removed regardless of the laboratory test results.
  - 2. Soil - If the geometric mean pre-job total lead concentration is less than 200 ppm, an impact is considered to have occurred if the post-job geometric mean lead concentration is an increase of 100 ppm or more. If the pre-job concentration is greater than 200 ppm, an impact is considered to have occurred if the post-job geometric mean lead concentration exceeds the pre-job geometric mean plus two (2) standard deviations, or an increase of 100 ppm occurs, whichever is greater.
  - 3. Sediment - The sediment will be considered to have been impacted from Project activities following the same criteria utilized for soils.
  - 4. Water - If the geometric mean pre-job total lead concentration is less than  $3.5 \mu\text{g}/\text{L}$ , an impact is considered to have occurred if the post-job geometric mean lead concentration is an increase of  $1.5 \mu\text{g}/\text{L}$  or more. If the pre-job concentration is greater than  $3.5 \mu\text{g}/\text{L}$ , an impact is considered to have occurred if the post-job geometric mean lead concentration exceeds the pre-job geometric mean plus two (2) standard deviations, or an increase of  $1.5 \mu\text{g}/\text{L}$  occurs, which ever is greater.
  - 5. If the laboratory analysis shows the soil, water or sediment to have been impacted by Project activities, as directed by the Chief Engineer, and at

## SPECIAL PROVISIONS

no cost to the Commission, conduct the clean-up or remediation necessary to return the media to pre-project levels.

### **3.05 WORK PRACTICES/CONTAINMENT**

#### **A. General Containment Requirements**

1. Use a containment system that maintains the Work area free of emissions of dust and debris in accordance with all requirements of this Special Provision.
2. Follow the containment requirements as specified in this item and as stipulated in SSPC Guide 6 for the selected method of removal as summarized in Table 1 of this Special Provision.
3. Have the existing bridge structure analyzed by a Licensed Professional Engineer registered in the State of Ohio. The purpose is to evaluate the loads and stresses imposed on the existing bridge structure by the containment system including wind load, erection loads, blast waste, worker and equipment live loads, as well as the existing structure dead loads, HS20-44 live loads, and impact loading all in accordance with the American Association of State Highway and Transportation Officials - Standard Specification for Highway Bridges, current edition and all interim specifications.
4. When feasible, use the same containment system for both surface preparation and the application of the coatings to prevent paint droplets or overspray from escaping the Work area. Vent the containment during spray application using a suitably sized fan and dust sock, or employ paint arrestor filters on the dust collector intake. Carefully monitor the dust sock or dust collector during spray-painting operations to assure that explosion hazards due to solvent concentrations do not exist.
5. Unless specifically approved by the Chief Engineer, equipment and workers are not allowed to be present or to operate over any lanes that are open to traffic.
6. Remove debris from the containment materials and equipment prior to relocation to another point along the structure or within the facility. Clean to the extent that debris or dust is not dislodged by winds or physical contact during handling and transportation.
7. If lift trucks or truck mounted platforms are utilized, decontaminate any equipment used within the regulated area at the end of each shift.

#### **B. Enclosure System**

1. If the floor or ground beneath the structure being prepared serves as the base of the containment, cover it with air and dust impenetrable materials such as solid panels of plywood or flexible materials such as tarpaulins. Maintain the materials throughout the Project to avoid losing debris through rips, tears, or breaks in the coverings.
2. Suspend containment materials or platforms from the bridge structure or parapet walls only when a structural analysis conducted by the Contractor confirms that the bridge components have adequate capacity.

## SPECIAL PROVISIONS

Make any attachments to the structure using rollers, hooks, slings, clamps or other methods, which will not require welding or drilling of holes in either the steel or concrete. Protect parapets from any scraping or gouging damage when hanger mechanisms are used. Do not allow any attachments to concrete parapet walls to Project into the deck shoulder area by more than nine inches (9”).

3. If a suspended or elevated platform is constructed to serve as the base of the containment, verify that the platform and its components are designed and constructed to support at least four (4) times its maximum intended load without failure with wire cables capable of supporting at least six (6) times their intended load without failure. Strictly follow all applicable OSHA regulations regarding scaffolding. Cover the platform or scaffolding with air and dust impenetrable materials.
4. Use only fire resistant, self-extinguishing materials.

### C. Containment Components

1. Table 1 - Table 1 identifies a series of components that serve as the basis for minimum requirements for the containment system for various methods of paint removal. The components are defined in this Special Provision.
2. Rigidity of Containment Materials - Rigid containment materials consist of solid panels of plywood, aluminum, rigid metal, plastic, fiberglass, composites, or similar materials. Flexible materials consist of screens, tarps, drapes, plastic sheeting, or similar materials.
3. Permeability of Containment Materials - The containment materials are identified as air impenetrable if they are impervious to dust or wind such as provided by rigid panels or coated solid tarps or plastic sheeting. Air penetrable materials are those that are formed or woven to allow air flow. Water impermeable materials are those that are capable of containing and controlling water when wet methods of preparation are used. Chemical resistant materials are those resistant to chemical and solvent stripping solutions.
4. Support Structure - Rigid support structures consist of scaffolding and framing to which the containment materials are affixed to minimize movement of the containment cocoon. Flexible support structures are comprised of cables, chains, or similar systems to which the containment materials are affixed. Minimal support structures involve nothing more than the cables or connections necessary to attach the material to the structure being prepared and/or to the ground.
5. Containment Joints - Fully sealed joints required that mating surfaces between the containment materials and to the structure being prepared are completely sealed. Sealing measures include tape, caulk, Velcro, clamps, or other similar material capable of forming a continuous, impenetrable or impermeable seal. Partially sealed joints involve the mating of the materials to one another and to the structure being prepared with concern for the structural soundness of the joint, but without consideration for creating a continuous, impenetrable or impermeable seal.



## SPECIAL PROVISIONS

6. Entryways - An airlock entryway involves a minimum of one (1) stage that is fully sealed to the containment and which is maintained under negative pressure using the ventilation system of the containment. Resealable door entryways involve the use of doors capable of being repeatedly opened and resealed. Sealing methods include the use of zippers, Velcro, clamps, or similar fasteners. Overlapping door tarpaulin entryways consist of two (2) or three (3) overlapping door tarpaulins. Open seam entryways involve entrance into the containment through any open seam.
  7. Mechanical Ventilation - The requirement for mechanical ventilation is to assure that adequate air movement is achieved to reduce worker exposure to toxic metals to as low as feasible, and to enhance visibility. The system must be designed with proper exhaust ports or plenums, adequately sized ductwork, discharge fans and air cleaning devices (dust collectors) and properly distributed make-up air points. Natural ventilation does not require the use of mechanical equipment for moving dust and debris through the Work area. It relies on natural air flow patterns, if any, through the containment.
  8. Negative Pressure - If negative pressure is specified, it can be verified by instrument monitoring to achieve a minimum of 0.03 in. (7.5 mm) water column (W.C.) relative to ambient conditions, or through visual assessments for the concave appearance of the containment enclosure.
  9. Exhaust Air Filtration - When mechanical ventilation systems are used, filtration of the exhaust air is necessary, otherwise airborne particulate from the containment will be exhausted directly into the surrounding air. Provide a filtration efficiency of at least 99.9% in removing particulate of 0.5 microns or better.
- D. Maintenance of Bridge Lighting Systems and Containment Lighting Requirements
1. Maintain all bridge lighting systems operational throughout the Project. Lighting includes navigation lights, aerial lighting, and roadway lighting.
  2. If existing lighting will be concealed (e.g., navigation lights), install temporary lighting. Provide the lighting plan to the Chief Engineer for approval in advance.
  3. Provide adequate lighting for all surface preparation, paint application, and inspection Work. Maintain a minimum of ten (10) foot-candles for surface preparation and painting, and a minimum of thirty (30) foot-candles for inspection. Increase the lighting if workers or inspectors have difficulty in seeing. Use explosion-proof lighting.
- E. Protection of Bridge Drainage Systems
1. Protect storm sewers and drains from the entrance of debris from Project activities. Keep all protective systems clean and operational throughout the entire Project. At the end of each workday at a minimum, remove all visible debris from the protective devices or from areas where rain water could carry the debris into drains or storm sewers. Conduct more frequent cleaning as directed by the Chief Engineer.

## SPECIAL PROVISIONS

2. Identify enclosure in the containment plan the methods that will be used to route run-off from the existing deck drains through the containment. Do not close any bridge deck drains without the explicit approval of the Chief Engineer.

### F. Work over Water - Containment Restrictions and Water Booms

1. When working over or near water, use water booms to contain inadvertent spills or releases of dust and debris unless prohibited by navigation lanes. In these cases, use a boat with a skimmer to collect fugitive materials. Remove all Project-related dust and debris from the surface of the water or from sediment at the end of each workday at a minimum. Conduct more frequent cleaning, if so directed by the Chief Engineer.

### 2. Coast Guard Issues and Notification

- (a) Provide the Chief Engineer and the Coast Guard with the distance that the containment will extend below the bottom of the bridge (e.g., below the bottom chord) when operating in the navigation channel. Maintain this distance to the absolute minimum required.
  - (b) Advance approval from the Coast Guard is required any time that the Work necessitates partial or total restrictions to the movement of vessels beneath the bridge. Provide the Coast Guard with the request at least thirty (30) days prior to the need to commence such activities.
  - (c) Unless otherwise directed by the Coast Guard, design the containment to allow it to be moved out of the navigation channel within twenty-four (24) hours of notification that ships needing additional clearance require passage.
3. Provide the Chief Engineer and the Coast Guard with a twenty-four (24) hour telephone number and contacts for discussions regarding the containment system.

## **3.06 WASTE CLASSIFICATION, HANDLING, AND DISPOSAL**

### A. General

1. The Commission is the generator of the hazardous waste for permitting purposes, and will provide the EPA identification number, but the Contractor is responsible for the handling, storage, transportation and disposal of all wastes.
2. Recover all waste products generated during cleaning and painting Work, including but not limited to rags, tape, disposable coveralls, filters, paint debris, and paint cans.
3. Conduct the Work in strict accordance with Federal, State, and Local regulations governing the handling, transportation and disposal of waste.

### B. Items Provided by the Commission

## SPECIAL PROVISIONS

1. An EPA ID number and signatures on the hazardous waste manifest.

### C. Items Provided by the Contractor

1. Containerizing, testing (classifying), handling, and storage of all waste.
2. Contracting with licensed and/or permitted waste transporters for the transportation of all hazardous and non-hazardous waste, as well as wastewater.
3. Contracting with licensed and/or permitted disposers of all waste.

### D. Waste Sampling, Testing, and Classification

#### 1. Solid Waste Sampling

- (a) Collect representative samples of the paint debris generated by Project activities. Collect all samples under the observation of the designees of the Chief Engineer.
- (b) Collect samples in accordance with SW-846, "Test Methods for Evaluating Solid Waste - Physical/Chemical Methods." Describe the sampling methods in the Waste Handling Plan.
- (c) All waste streams generated through the use of steel grit abrasives are declared hazardous, but collect a minimum of one (1) representative sample of the waste stream(s) generated from the use of steel grit to identify the specific composition.
- (d) Collect a minimum of four (4) representative samples of all other waste streams (i.e., all waste streams, which were not generated by blast cleaning with steel abrasives.) These waste streams include, but are not limited to: paint chips and dust, paint chips mixed with disposable abrasives, and chemical stripping debris. Use a random sampling technique for the collection of the initial samples of each waste stream, and from that group, use random sampling again to select the four (4) for testing.
- (e) Complete the initial sampling of each waste stream immediately upon filling the first container, but do not allow waste to accumulate for longer than thirty (30) days before sampling. After the representative samples are collected, send them immediately to the laboratory for analysis.
- (f) Unless otherwise directed by the Chief Engineer, or required by state regulations or the waste disposal facility, once each waste stream is sampled, tested, and classified, additional sampling and analysis are not required for subsequent shipments unless the waste stream changes.

## SPECIAL PROVISIONS

### 2. Wastewater

- (a) Collect representative samples of wastewater generated by the Work. At a minimum, collect and analyze one (1) sample per storage container. Collect the samples under the observation of the designee of the Chief Engineer.
- (b) Complete the initial sampling of each wastewater stream immediately upon filling the first container, but do not allow waste to accumulate for longer than thirty (30) days before sampling. After the representative samples are collected, send them immediately to the laboratory for analysis.

### 3. Testing (Solid Waste)

- (a) Have all testing performed by the laboratory accepted to the Chief Engineer. Direct the laboratory to test the waste in accordance with 40 CFR 261, Appendix II, Method 1311, Toxicity Characteristic Leaching Procedure (TCLP), to determine if it is hazardous. Note that spent solvents and unused paint can be classified as hazardous due to ignitability without the need for testing.
- (b) Analyze the first two (2) samples from each waste stream by TCLP for all eight (8) heavy metals and other hazardous substances. Analyze subsequent samples of the waste stream(s) for lead and any material that is detected in the initial TCLP testing. For recyclable steel grit debris that will be treated as hazardous, analyze one (1) sample for all eight (8) metals. When chemical strippers are used, test all liquids and sludge. Include pH to determine corrosivity.

### 4. Testing (Wastewater)

- (a) Test the wastewater for total lead, cadmium, arsenic, and chromium and any other analytical parameters required for disposal characterization or by the disposal facility.

### 5. Classification

- (a) Paint debris is classified as hazardous waste if the leachate contains any of the eight (8) metals or other hazardous substances in concentrations at or above limits established in 40 CFR 261.

Arsenic -	5.0 mg/L
Barium -	100.0 mg/L
Cadmium -	1.0 mg/L
Chromium -	5.0 mg/L
Lead -	5.0 mg/L
Mercury -	0.2 mg/L
Selenium -	1.0 mg/L
Silver -	5.0 mg/L

## SPECIAL PROVISIONS

- (b) The above includes only those elements typically associated with paints. Other substances may be present which may cause debris to be classified as hazardous waste as defined in 40 CFR 261 (e.g.,  $\text{pH} \leq 2.0$  or  $\geq 12.5$  resulting in corrosivity, or the characteristic of ignitability) and must be taken into account.

### 6. Report

- (a) Provide the Chief Engineer with copies of the test results as soon as they are received from the laboratory, and no later than ten (10) days after the representative samples are collected and no later than forty (40) days after start-up.
- (b) Identify the waste stream(s) analyzed, the number of samples collected and tested, dates of sampling and testing, laboratory test procedures utilized, and the names of the individuals collecting the samples and conducting the laboratory tests. Include copies of the chain-of-custody forms in the documentation.

### E. Waste Handling, Packaging, and Storage

1. Comply with 40 CFR 262 and Ohio Revised Code, Chapter 37, for the on-site handling, packaging, and storage of all hazardous waste generated by the Project.
2. Comply with Ohio Revised Code, Chapter 37, for the handling, packaging, and storage of non-hazardous construction waste. Comply with additional County and City regulations as applicable.
3. At a minimum, collect and store the waste at the end of each working day in storage drums or containers such that no waste is left uncontained overnight. Use ODOT-approved containers for hazardous waste storage.
4. Cover all containers and attach lids immediately upon filling. Verify that all labels remain intact.
5. Locate all waste in a single secure storage area with signs around the perimeter. Contact the Chief Engineer for approval of the storage location(s.) At no time should more than one (1) drum of waste remain outside of the secure storage area for more than three (3) days.
6. Store non-hazardous waste separately from hazardous waste. Do not co-mix hazardous waste with non-hazardous waste.
7. Arrange containers in the storage area for easy accessibility and maintain clearance between containers.
8. Do not store any waste on-site for longer than sixty (60) days.
9. Improper waste storage is caused for immediate Project shut down until appropriate corrective action is completed.
10. Train all personnel in the proper handling of the hazardous waste at the Work site in accordance with 40 CFR 265.16. Include procedures in the

## SPECIAL PROVISIONS

Waste Handling Plan that will be followed in the event of a release or spill, required notifications, and methods to be used for cleanup. Maintain all training records on-site.

11. Do not fill any container or roll-off in excess of the capacity marked on the container.
12. If soil remediation is required as a result of Contractor activities, place the soil into separate containers. The Contractor is responsible for the cost of its disposal.

### F. Labeling of Containers

1. Immediately label all containers of Project waste and debris to identify the contents. For recyclable steel grit debris that will be treated as hazardous, immediately label the waste as hazardous. Maintain all labels throughout the Project.
2. After the TCLP test results are received, immediately apply hazardous waste labels, if the waste tests hazardous. Label each container or roll-off of hazardous waste in accordance with 40 CFR 262, 49 CFR 171-179, and Ohio Revised Code, Chapter 37. Include the following minimum information:
  - (a) Hazardous Waste. Federal law prohibits improper disposal. If found, contact the nearest police, or public safety authority, or the U.S. Environmental Protection Agency.
  - (b) Proper ODOT Shipping Name.
  - (c) Manifest Document No.
  - (d) Generator Name, Address, and EPA ID No.
  - (e) Date of Accumulation.
  - (f) EPA Waste No.
3. Apply non-hazardous waste classification labels on all other Project waste in accordance with Ohio Revised Code, Chapter 37.
4. Enter the above information using permanent marking material, printed in English, and displayed on a background of contrasting color unobscured by other labels or attachments.
5. All labeling, marking, and placarding is the responsibility of the Contractor. Complete the labeling activities under the observation of the designee of the Chief Engineer, prior to storing or transporting any container or roll-off.

### G. Waste Transportation and Disposal

1. Advise the Chief Engineer at least two (2) days in advance of each shipment. Prepare the hazardous waste manifest for each shipment and provide to the Chief Engineer for review and signature.

## SPECIAL PROVISIONS

### 2. Hazardous Waste

- a) Arrange for the transportation of all hazardous waste by a licensed transporter in accordance with 40 CFR 263, 49 CFR 171-179, and Ohio Revised Code, Chapter 37. Also comply with applicable County or City regulations
- (b) Arrange for the disposal of all hazardous waste in accordance with 40 CFR 264, 40 CFR 268, and Ohio Revised Code, Chapter 37.
- (c) Comply with all of the manifesting, certification, and reporting requirements for hazardous waste in accordance with 40 CFR 262, 40 CFR 268, Ohio Revised Code, Chapter 37, including provision of certificates of final disposal to the Chief Engineer for each shipment.

### 3. Non-Hazardous Construction Waste

- (a) Transport, and dispose of all residual and non-hazardous construction waste in accordance with Ohio Revised Code, Chapter 37.
- (b) Comply with additional County and City regulations as applicable.

### H. Special Handling and Disposal Conditions for Waste Resulting from the Use of Recycled Steel Grit Abrasives

1. When recycled steel grit abrasives are used, and the resulting waste tests non-hazardous, notify the waste disposal facility that the waste contains high levels of lead and that further stabilization is required prior to disposal. Use stabilization methods that would have been used in the event the waste tested hazardous.
2. Comply with the requirements for the site handling and storage of the waste as if it tested hazardous.

### I. Special Handling and Disposal Conditions for Wastewater

1. Provide containers for the collection and retention of all wastewater, including but not limited to the water used for paint removal, hygiene purposes, laundering of clothing, and cleanup activities.
2. Filter visible paint chips and particulate (e.g., through a multi-stage filtration system ending in five (5) microns or better if needed) from the water prior to placing it into the containers. Prior to disposal, test the water for total toxic metals in accordance with these Special Provisions and provide ample filtration until the water is not classified as hazardous.
3. Provide the Chief Engineer with documentation from the facility stating that they will accept the wastewater, and that the levels of any lead or other toxic metals remaining in the water are acceptable.

## SPECIAL PROVISIONS

### J. Recordkeeping

Provide the following information to the Chief Engineer for a retention period of a minimum of five (5) years: all manifests, a listing of the type and quantity of all waste generated, and the transportation and disposal facilities used for all waste.

3.07

## **CLEANING AND CLEARANCE OF MATERIALS, EQUIPMENT, AND SURROUNDING SURFACES**

### A. Contractor Materials and Equipment

1. Upon completion of Project activities, remove all Contractor equipment and materials. Thoroughly vacuum, wash, or otherwise decontaminate reusable items until they are visually clean prior to removal from the Project site. These items include, but are not limited to, paint removal equipment, containment materials, ground covers, and scaffolding.
2. If adequate cleaning is not possible, treat materials as waste and dispose of in accordance with these Special Provisions.
3. Collect water used for cleaning and dispose of in accordance with these Special Provisions.

### B. Cleaning of Surrounding Property and Surfaces

1. General Inspection and Cleaning Requirements
  - (a) Upon completion of Project activities, and after all Contractor equipment and materials have been removed, conduct an inspection of the Project site and surrounding property and surfaces located within the likely dispersion zone of Project dust and debris.
  - (b) Thoroughly inspect the property and surfaces for the presence of Project-generated debris including, but not limited to spent abrasives or other paint removal media, paint chips, materials of construction, fuel, and other litter.
  - (c) After all clean up activities are completed, conduct a final inspection with the designee of the Chief Engineer. Conduct any additional cleaning identified by the Chief Engineer.
2. Cleaning Requirements
  - (a) Remove all Project debris and litter from the Project site and surrounding property, equipment, and structures.
  - (b) When cleaning paint chips and dust, use HEPA vacuums, wet washing, or other means that will effectively remove the dust and debris without re-dispersing it into the air. The use of compressed air for cleanup activities is prohibited unless used in conjunction with a ventilation system designed to capture the airborne particulate.
  - (c) Collect water used for cleaning and dispose of in accordance with these Special Provisions.



## SPECIAL PROVISIONS

### 3. Acceptance Criteria - Project Cleanup

- (a) Clean up activities will be considered to be successfully completed under the conditions identified below.
- (b) Paint chips, spent abrasive and other paint removal media, fuel, materials of construction, litter, or other Project debris are not visible on or around the Project site.
- (c) Lead dust has been removed from the surface of the completed structure as well as from surrounding structures and equipment when assessed visually.

### 4. Remediation of Surrounding Property

If directed by the Chief Engineer, conduct the necessary remediation of soil, water, and/or sediment if impacted by Project activities as described earlier in these Special Provisions.

### 5. Report on Clearance Inspection

Prepare a letter report presenting the results of the inspections and tests conducted to verify the final cleanliness of the Project site, surrounding property, waterways, equipment, buildings, and structures. Provide this report to the Chief Engineer within ten (10) days after demobilization.

## **3.08 REPORTABLE RELEASES**

### A. Clean Water Act

Reportable quantities of hazardous substances in waterways are found in Section 311 of the Clean Water Act. Report such releases to the Chief Engineer, the EPA in accordance with 40 CFR 117 and 40 CFR 355, and the Coast Guard.

### B. CERCLA

Reportable quantities under CERCLA are found in 40 CFR 302. In the case of lead, the reportable quantity is a release of ten (10) or more pounds in a twenty-four (24) hour period. If such releases occur, stop Work immediately and notify the Chief Engineer and the National Response Center (800/424-8802.)

## **PART 4.0 MEASUREMENT AND PAYMENT**

### **4.01 METHOD OF MEASUREMENT**

- A. All worker protection requirements for Contractor personnel, including protective clothing and equipment, medical surveillance, hygiene facilities, laundering, and documentation, are based on lump sum.
- B. Protective clothing and equipment for designees of the Chief Engineer is based on a unit price basis. The price represents full compensation for the equipment and its cleaning or disposal. For estimating purposes, two (2) sets of clothing and equipment should be available for Commission use for each eight (8) hour shift, with an average of two (2) additional sets available per week.

## SPECIAL PROVISIONS

- C. Regulated area monitoring is based on lump sum and includes full compensation for all equipment needed, personnel time, laboratory fees, and documentation for the establishment and monitoring of the regulated area(s) throughout the duration of the Project.
- D. Non-hazardous waste is not measured for payment. All costs associated with the collection, storage, transportation, and disposal of non-hazardous waste are considered to be incidental to the Project.
- E. Paint waste/hazardous waste is based on lump sum, and includes full compensation for all testing, handling, storage, transportation, and disposal of the waste.
- F. Containment is based on lump sum, and includes full compensation for all labor, containment and ventilation materials and equipment, engineering, drawings, and any equipment or facilities needed to install, operate, move, clean, dismantle, and remove the containment system from the Project site.

### **4.02 BASIS OF PAYMENT**

- A. Payment for accepted quantities will be made at the Contract unit price. Payment represents full compensation for all labor, materials, tools, equipment, and other incidentals necessary to complete each item.
- B. All of the items identified below apply to either localized or total removal of the existing coatings.

<u>Items</u>	<u>Units</u>	<u>Description</u>
SP 525A	Lump Sum	Worker Protection
SP 525A	Each	Protective Clothing/Equipment Set
SP 525A	Lump Sum	Establish Regulated Areas
SP 525A	Lump Sum	Paint Waste/Hazardous Waste Classification, Handling, and Disposal
SP 525A	Lump Sum	Containment System

- C. The Contractor shall include all Work required by SP 525B as incidental to the above pay Items.

### **4.03 PAYMENT SCHEDULE**

- A. Partial payments for Item SP 525A - Worker Protection will be made by prorating the Contract Lump Sum price for the item based on dividing the calendar days of time expended on the jobsite by the anticipated duration of the Project in calendar days as shown on the most recently approved Progress Schedule.
- B. Payment for Item SP 525A - Protective Clothing/Equipment Set will be made at the Contract price for each clothing/equipment set used. No partial payments will be made.
- C. Partial payments for Item SP 525A - Establish Regulated Areas will be made by prorating the Contract Lump Sum price for the item based on dividing the

## SPECIAL PROVISIONS

calendar days of time expended on the job site by the anticipated duration of the Project in calendar days as shown on the most recently approved Progress Schedule.

- D. Payment for Item SP 525A - Paint Waste/Hazardous Waste Classification, Handling, and Disposal will be made at the Contract Lump Sum price for the item. Partial payments will not be made for this item. Payment will not be made until all certificates of final disposal are provided to the Chief Engineer.
- E. Partial payments of Item SP 525A - Containment Systems will be made by prorating the Contract Lump Sum price for the item based on dividing the surface area that has been prepared and coated with all three coats by the total surface area of the structure.

## SPECIAL PROVISIONS

**Table 1  
Containment Criteria for Removal of Paint Containing Lead and Other Toxic Metals<sup>1</sup>**

<u>Removal Method</u>	<u>SSPC Class<sup>2</sup></u>	<u>Containment Material Flexibility</u>	<u>Containment Material Permeability<sup>3</sup></u>	<u>Containment Support Structure</u>	<u>Containment Material Joints</u>	<u>Containment Entryway</u>	<u>Ventilation System Required</u>	<u>Negative Pressure Required</u>
Hand Tool Cleaning <sup>4</sup>	3P	Rigid or Flexible	Permeable or Impermeable	Minimal	Partially Sealed	Overlapping or Open Seam	Natural	No
Power Tool Cleaning w/ Vacuum <sup>4</sup>	3P	Rigid or Flexible	Permeable or Impermeable	Minimal	Partially Sealed	Overlapping or Open Seam	Natural	No
Power Tool Cleaning w/o Vacuum <sup>5</sup>	2P	Rigid or Flexible	Permeable or Impermeable	Rigid or Flexible	Fully or Partially Sealed	Overlapping or Open Seam	Natural <sup>5</sup>	No
Chemical Required <sup>6</sup> Stripping <sup>6</sup>	3C	Rigid or Flexible	Permeable or Impermeable	Minimal	Partially Sealed	Open Seam	Natural	No
Wet Methods <sup>7</sup>	2W-3W	Rigid or Flexible	Permeable or Impermeable	Rigid, Flexible, or Minimal	Partially Sealed	Overlapping or Open Seam	Natural <sup>7</sup>	No
Abrasive Blast Cleaning <sup>8</sup>	1A	Rigid or Flexible	Impermeable	Rigid or Flexible	Fully Sealed	Airtight or Resealable	Mechanical	Yes

<sup>1</sup>This table provides general design criteria only. It does not guarantee that specific controls over emissions will occur because unique site conditions must be considered in the design. Other combinations of materials may provide controls over emissions equivalent to or greater than those combinations shown above.

<sup>2</sup>The SSPC Classification is based on SSPC Guide 6. Note that for Work over water, water booms should be employed, where feasible, to contain spills or releases. Debris must be removed daily at a minimum.

<sup>3</sup>Permeability addresses both air and water as appropriate. In the case of water or chemical removal methods, the containment materials must be resistant to both chemicals and water. Ground covers should always be impermeable, and of sufficient strength to withstand the impact and weight of the debris and the equipment that might be used for collection and clean-up.

<sup>4</sup>Ground covers and/or free hanging tarpaulins may provide suitable controls over emissions without the need to completely enclose the Work area.

<sup>5</sup>Ventilation is not required provided the emissions are controlled as specified in this section, and provided worker exposures are properly controlled. If unacceptable worker exposures to lead or other toxic metals occurs, incorporate a ventilation system into the containment.

<sup>6</sup>Ground covers must always be impermeable and of sufficient strength to withstand the weight and impact of the debris and the equipment used for cleaning. If debris escape through the seams, then additional sealing of the seams and joints is required. All containment materials and materials used for sealing must be resistant to both chemicals and water. If unacceptable worker exposures to lead or other toxic metals occurs, incorporate a ventilation system.

<sup>7</sup>This method applies to pressure washing, high pressure water jetting with and without abrasive, and wet abrasive blast cleaning. Although both permeable and impermeable containment materials are included, ground covers and the lower portions of the containment must be water impermeable with fully sealed joints, and of sufficient strength and integrity to facilitate the collection and holding of the water and debris for proper disposal. Ventilation is not required provided the emissions are controlled as specified in this section, and provided worker exposures are properly controlled. If unacceptable worker exposures to lead or other toxic metals occurs, incorporate a ventilation system into the containment.

## SPECIAL PROVISIONS

<sup>8</sup>Ground covers must be of sufficient strength to withstand the impact and weight of the abrasive and the equipment used for cleaning. Ground covers should also extend beyond the containment boundary to capture escaping debris.



# OHIO TURNPIKE AND INFRASTRUCTURE COMMISSION

## THE JAMES W. SHOCKNESSY OHIO TURNPIKE

### PROJECT NO. 43-18-04

# BRIDGE DECK REPLACEMENT AND REHABILITATION

## OHIO TURNPIKE OVER WHEELING & LAKE ERIE RAILWAY, M.P. 186.0, INTERSTATE ROUTE 480 EASTBOUND OVER OHIO TURNPIKE, M.P. 186.8 PORTAGE COUNTY, OHIO

#### OHIO TURNPIKE AND INFRASTRUCTURE COMMISSION STANDARD DRAWINGS

AS-1	REINFORCED CONCRETE APPROACH SLABS
CB-2	CATCH BASIN, NO. CB-1 RECONSTRUCTED
CB-4	INLET, NO. I-3B50 DOUBLE GRATE
CBM-6	B-50 BARRIER TRANSITION AND MEDIAN WALL DETAILS
CBR-1	CONCRETE BARRIER, TYPE B-50 AND C-50, AS PER PLAN
CL-2	CHAIN LINK SAFETY FENCE (ALL ALUMINUM) DETAILS, TYPE 2
DJ-1	DECK JOINT DETAILS, CELLULAR ABUTMENTS
DJ-2	DECK JOINT DETAILS
DJ-4	DECK JOINT DETAILS, SPILL-THRU ABUTMENTS
RPM-1	RAISED PAVEMENT MARKER AND STRIPING LAYOUT
TC-1	TRAFFIC CONTROL BRIDGE AND BARRIER SIGN SUPPORT DETAILS
TC-3	TRAFFIC CONTROL MAINLINE DELINEATION
TCB-1	REQUIREMENTS FOR PORTABLE BARRIER SETTING AND REMOVAL OPERATIONS
TCB-2	PORTABLE BARRIER STORAGE DETAILS
TCR-1	TEMPORARY TRAFFIC CONTROL GENERAL NOTES
TCR-2	TEMPORARY TRAFFIC CONTROL DETAILS, LEGEND, NOTES AND STANDARD SINGLE LANE CLOSURE
TCR-4	TEMPORARY TRAFFIC CONTROL BI-DIRECTIONAL ROADSIDE DELINEATION
TCR-7	TEMPORARY TRAFFIC CONTROL TWO LANE CROSSOVER DETAILS
TCR-9	TEMPORARY TRAFFIC CONTROL SHORT DURATION/SHORT TERM SHOULDER CLOSURE
TCR-10	TEMPORARY TRAFFIC CONTROL DOUBLE LANE CLOSURE
TCR-11MZ	TEMPORARY TRAFFIC CONTROL FOR SINGLE LANE MOBILE OPERATION
TCR-12.1	TEMPORARY TRAFFIC CONTROL DOUBLE LANE SHIFT ZONE IN 3-LANE SECTION
TCR-13	SONIC NAP ALERT PATTERN (SNAP)
TCR-14	TEMPORARY TRAFFIC CONTROL SINGLE LANE CLOSURE WITH PORTABLE BARRIER
TCR-15	TEMPORARY TRAFFIC CONTROL SIGNS FOR MAINTENANCE AND CONSTRUCTION
XOV-3	MAINTENANCE CROSSOVER DETAILS

#### OHIO DEPARTMENT OF TRANSPORTATION STANDARD DRAWINGS

AS-1-15	REINFORCED CONCRETE APPROACH SLAB	07/17/15
AS-2-15	REINFORCED CONCRETE APPROACH SLAB INSTALLATION	07/17/15
BP-3.1	ASPHALT PAVING	07/18/14
BP-5.1	CONCRETE CURBS AND COMBINED CURB & GUTTER	07/19/13
BP-9.1	SHOULDER RUMBLE STRIPS	07/21/17
CB-2.3	CATCH BASIN NO. 6	01/15/16
DM-1.1	OUTLETS, DRAINS, AND SEWERS	07/21/17
DM-1.3	SLOTTED DRAINS	07/18/14
HL-10.13	POLE BASE DETAILS	01/20/17
HL-20.11	MISCELLANEOUS LIGHT POLE FOUNDATION AND TRENCH DETAILS	04/21/17
MGS-1.1	MGS GUARDRAIL DETAILS	07/21/17
MGS-2.1	STANDARD TYPE MGS	07/19/13
MGS-3.1	MGS BRIDGE TERMINAL ASSEMBLY, TYPE 1	07/21/17
MGS-3.2	MGS BRIDGE TERMINAL ASSEMBLY, TYPE 2	01/18/13
MGS-4.3	MGS GUARDRAIL TRANSITIONS	01/18/13
MGS-6.1	MGS GUARDRAIL AT BRIDGES	07/19/13
MT-95.30	CLOSING LEFT OR RIGHT LANE OF A MULTI-LANE DIVIDED HIGHWAY WITH DRUMS	07/21/17
MT-95.40	CLOSING LEFT OR RIGHT LANE OF A MULTI-LANE DIVIDED HIGHWAY WITH PORTABLE CONCRETE BARRIER	01/20/17
MT-95.45	CLOSING SHOULDER OF A MULTI-LANE DIVIDED HIGHWAY	07/21/17
MT-95.50	SUPPLEMENTAL ADVANCED SIGNS USED WITH LANE CLOSURES	07/21/17
MT-95.70	MEDIAN CROSSOVER-SINGLE LANE	07/21/17
MT-95.71	MEDIAN CROSSOVER-MULTI LANE	07/21/17
MT-98.10	LANE CLOSURE AT ENTRANCE RAMP	01/20/17
MT-98.20	LANE CLOSURE AT EXIT RAMP USING DRUMS	07/18/14
MT-99.30	WORK ZONE DELINEATION	07/21/17
MT-100.00	WORK ZONE CROSSOVER LIGHTING SYSTEM	01/15/16
MT-101.60	ROAD CLOSURE USING TYPE 3 BARRICADES	01/20/17
MT-101.70	BARRIER AND IMPACT ATTENUATOR DELINEATION	01/17/14
MT-101.75	IMPACT ATTENUATOR PLACEMENT	07/15/16
MT-101.80	PCB TO PERMANENT BARRIER TRANSITIONS	01/16/15
MT-101.90	DROP-OFFS IN WORK ZONES	07/21/17
MT-102.10	LANE SHIFT SIGNING INCORPORATION SPEED LIMIT AND PENALTIES SIGNING	01/20/17
MT-104.10	WORK ZONE SPEED ZONES(WZSzs) ON HIGH-SPEED(>=55 MPH) MULTI-LANE HIGHWAYS	10/16/15
MT-105.10	TEMPORARY SIGN SUPPORT	07/19/13
PCB-91	PORTABLE CONCRETE BARRIER DETAILS	01/18/13
RM-4.2	32" PORTABLE CONCRETE BARRIER	04/18/14
SBR-1-13	SINGLE SLOPE CONCRETE BRIDGE RAILING	01/17/14

#### OHIO DEPARTMENT OF TRANSPORTATION STANDARD DRAWINGS (CONTINUED)

TC-12.30	CANTILEVER OVERHEAD SIGN SUPPORT	01/20/17
TC-21.10	SIGN SUPPORT FOUNDATIONS	07/21/17
TC-21.20	SIGN SUPPORT FOUNDATIONS	07/21/17
TC-52.10	SIGN BLANK DETAILS 1	10/18/13
TC-52.20	SIGN BLANK DETAILS 2	07/21/17
TC-65.10	RAISED PAVEMENT MARKER PLACEMENT DETAILS	01/17/14
TC-65.11	RAISED PAVEMENT MARKER SPACING DETAILS	07/21/17
TC-72.20	FREEWAY AND EXPRESSWAY ENTRANCE AND EXIT PAVEMENT MARKINGS	07/15/16

#### OHIO DEPARTMENT OF TRANSPORTATION SUPPLEMENTAL SPECIFICATIONS

SS800	REVISIONS TO THE 2016 CONSTRUCTION AND MATERIAL SPECIFICATIONS	07/21/17
SS821	ARROW BOARD	04/20/12
SS832	TEMPORARY SEDIMENT AND EROSION CONTROL	01/17/14
SS921	ARROW BOARD	04/20/12

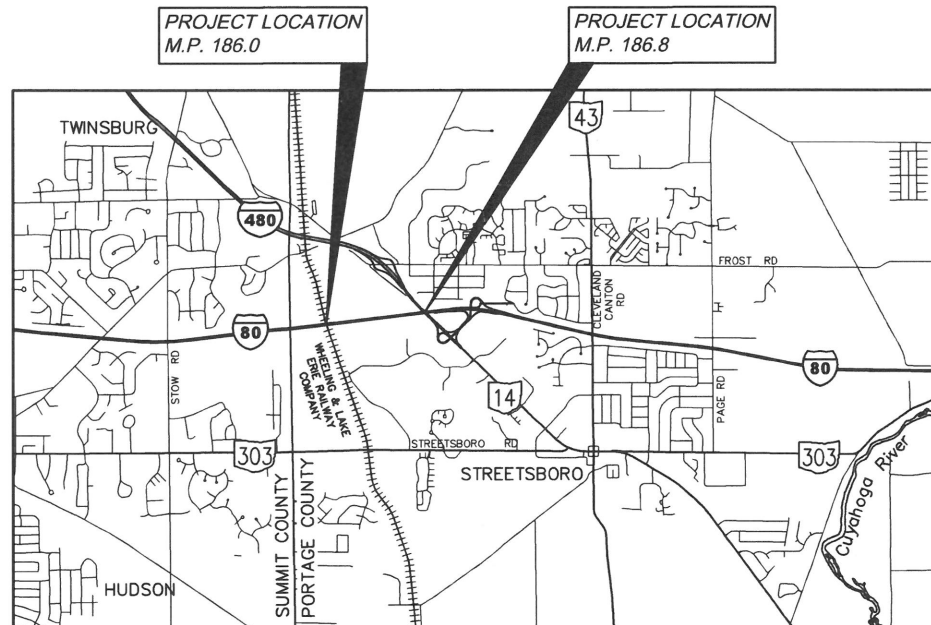

#### INDEX OF SHEETS

TITLE SHEET	1
GENERAL SUMMARY	2(3A)
MAINTENANCE OF TRAFFIC GENERAL NOTES M.P. 186.0 AND M.P. 186.8	4-9
MAINTENANCE OF TRAFFIC TYPICAL SECTIONS M.P. 186.0	10-15
MAINTENANCE OF TRAFFIC PLANS M.P. 186.0	16-39
MAINTENANCE OF TRAFFIC GEOMETRIC PLAN DETAILS M.P. 186.0	40-54
MAINTENANCE OF TRAFFIC TEMPORARY DRAINAGE DETAILS M.P. 186.0	55-59
MAINTENANCE OF TRAFFIC TYPICAL SECTIONS M.P. 186.8	60-61
MAINTENANCE OF TRAFFIC PLANS M.P. 186.8	62-72
STRUCTURES GENERAL NOTES M.P. 186.0 AND M.P. 186.8	73
STRUCTURES PLANS M.P. 186.0	74-89
STRUCTURES PLANS M.P. 186.8	90-102
APPROACH SLAB DETAILS M.P. 186.8	103
ROADWAY GENERAL NOTES M.P. 186.0 AND M.P. 186.8	104-105
ROADWAY PLAN M.P. 186.0	106-107
ROADWAY PROFILE M.P. 186.0	108-109
ROADWAY AND GEOMETRY PLAN M.P. 186.8	110-112
ROADWAY PROFILE M.P. 186.8	113

APPROVED FOR  
THE OHIO TURNPIKE AND INFRASTRUCTURE COMMISSION  
*Anthony D. York*  
CHIEF ENGINEER

1-22-18  
DATE

ENGINEERS SEAL: (SHEETS 1-72,104-113)	ENGINEERS SEAL: (SHEETS 73-103)	<b>UNDERGROUND UTILITIES</b> CONTACT BOTH SERVICES CALL TWO WORKING DAYS <b>BEFORE YOU DIG</b> CALL 1-800-362-2764 (TOLL FREE) OHIO UTILITIES PROTECTION SERVICE NON-MEMBERS MUST BE CALLED DIRECTLY OIL & GAS PRODUCERS PROTECTIVE SERVICE CALL: 1-800-925-0988 OHIO TURNPIKE DIVISION SUPERINTENDENT: (440) 821-3366
SIGNED: Mitchell A. McCoy DATED: 10-25-17	SIGNED: Matthew L. Johnson DATED: 10-23-2017	

PLAN PREPARED BY:  
  
PALMER ENGINEERING  
460 WHITE POND DRIVE, SUITE 300  
ENGINEERING AKRON, OHIO 44320  
CINCINNATI ■ AKRON ■ LEXINGTON ■ TALLAHASSEE ■ ORLANDO

711609\_GG001.dwg; 1/12/18 - 11:54am

GENERAL SUMMARY						
ITEM NO.	TOTAL	UNIT	DESCRIPTION	GENERAL	M.P. 186.0	M.P. 186.8
GENERAL						
IB.ART.6	1	LUMP	PREMIUM FOR CONTRACT PERFORMANCE BOND AND PAYMENT BOND	LUMP		
SP 119	1	LUMP	RAILROAD PROTECTIVE LIABILITY INSURANCE	LUMP		
SP 614	1	LUMP	MAINTAINING TRAFFIC		LUMP	
614	1	LUMP	MAINTAINING TRAFFIC			LUMP
SP 619	1	LUMP	FIELD OFFICE	LUMP		
SP 623	1	LUMP	CONSTRUCTION LAYOUT SURVEY	LUMP		
624	1	LUMP	MOBILIZATION	LUMP		
ROADWAY						
202	690	SQ. YD.	APPROACH SLAB REMOVED		400	290
202	191	SQ. YD.	PAVEMENT REMOVED			191
202	520	FOOT	CURB REMOVED		466	54
202	22	FOOT	PIPE REMOVED, 24" AND UNDER			22
202	950	FOOT	GUARDRAIL REMOVED		525	425
202	2	EACH	ANCHOR ASSEMBLY REMOVED, TYPE E			2
202	6	EACH	BRIDGE TERMINAL ASSEMBLY REMOVED		4	2
202	1	EACH	CATCH BASIN REMOVED			1
203	225	CU. YD.	EXCAVATION			225
203	6	CU. YD.	EMBANKMENT			6
204	1,741	SQ. YD.	SUBGRADE COMPACTION		1,064	677
204	124	CU. YD.	EXCAVATION OF SUBGRADE		124	
251	500	SQ. YD.	PARTIAL DEPTH PAVEMENT REPAIR	500		
255	500	SQ. YD.	FULL DEPTH PAVEMENT REMOVAL AND RIGID REPLACEMENT	500		
255	500	SQ. YD.	FULL DEPTH PAVEMENT REMOVAL AND RIGID REPLACEMENT (USING RAPID REPAIR CONCRETE MIX MATERIAL)	500		
255	1,500	FOOT	FULL DEPTH PAVEMENT SAWING	1,500		
254	14,517	SQ. YD.	PAVEMENT PLANING, ASPHALT CONCRETE, VARIABLE DEPTH		13,676	841
254	407	SQ. YD.	PATCHING PLANED SURFACE		365	42
302	95	CU. YD.	ASPHALT CONCRETE BASE, PG64-22			95
304	113	CU. YD.	AGGREGATE BASE, AS PER PLAN			113
SP 304	106	CU. YD.	AGGREGATE BASE		106	
SP 402	557	CU. YD.	ASPHALT CONCRETE INTERMEDIATE COURSE, USING CRUSHED STONE, PG64-22		557	
SP 403	165	CU. YD.	ASPHALT CONCRETE LEVELING COURSE, PG70-22		165	
SP 404	342	CU. YD.	ASPHALT CONCRETE SURFACE COURSE, USING CRUSHED STONE, PG64-22		342	
SP 404	192	CU. YD.	ASPHALT CONCRETE SURFACE COURSE, USING CRUSHED SLAG, PG70-22 (FR)		192	
SP 402	224	CU. YD.	ASPHALT CONCRETE INTERMEDIATE COURSE, PG70-22		224	
407	2,550	GAL.	NON-TRACKING TACK COAT		2,378	172
441	11	CU. YD.	ASPHALT CONCRETE INTERMEDIATE COURSE, TYPE 1, (448), (UNDER GUARDRAIL), AS PER PLAN			11
442	51	CU. YD.	ASPHALT CONCRETE SURFACE COURSE, 12.5 mm, TYPE A (448), AS PER PLAN			51
442	59	CU. YD.	ASPHALT CONCRETE INTERMEDIATE COURSE, 19mm, TYPE A (448)			59
526	426	SQ. YD.	REINFORCED CONCRETE APPROACH SLABS, AS PER PLAN (T=12")		426	
526	292	SQ. YD.	REINFORCED CONCRETE APPROACH SLABS (T=15")			292
526	137	FOOT	TYPE A INSTALLATION			137
601	4	SQ. YD.	TIED CONCRETE BLOCK MAT, TYPE 1			4
605	224	FOOT	6" UNCLASSIFIED PIPE UNDERDRAINS WITH GEOTEXTILE FABRIC			224
606	1,001	FOOT	GUARDRAIL, TYPE MGS		538	463
606	2	EACH	ANCHOR ASSEMBLY, MGS TYPE E			2
606	4	EACH	MGS BRIDGE TERMINAL ASSEMBLY, TYPE 1		2	2
606	2	EACH	MGS BRIDGE TERMINAL ASSEMBLY, TYPE 2		2	
SP 607	600	FOOT	TEMPORARY FENCE (7'-0" CHAIN LINK WITH SPECIALS)		600	
609	460	FOOT	ASPHALT CONCRETE CURB, TYPE 1		460	
609	43	FOOT	CURB, TYPE 4C		6	37
611	75	FOOT	6" CONDUIT, TYPE F, 707.33			75
611	24	FOOT	12" CONDUIT, TYPE F, 707.33			24
611	1	EACH	CATCH BASIN, NO. 3A			1
611	2	EACH	PRECAST REINFORCED CONCRETE OUTLET			2
SP 611	4	EACH	CATCH BASIN RECONSTRUCTED TO GRADE, LESS THAN 4"		4	
614	100	HOUR	LAW ENFORCEMENT OFFICER WITH PATROL CAR FOR ASSISTANCE			100
614	16	EACH	WORK ZONE IMPACT ATTENUATOR (UNIDIRECTIONAL)		8	8
614	2	EACH	WORK ZONE INCREASED PENALTY SIGNS			2
614	20	EACH	REPLACEMENT SIGN	20		
614	200	EACH	REPLACEMENT DRUM	200		
614	1	EACH	WORK ZONE LIGHTING SYSTEM			1

**GENERAL SUMMARY**

DESIGNED: DAM  
DRAWN: TES

CHECKED: MAM  
IN CHARGE: MAM

NO. 1  
2

REVISIONS:  
ADDENDUM 1  
ADDENDUM 2

BY DATE:  
DAM 01/18  
TES 01/18

DESIGN AGENCY:  
PALMER ENGINEERING  
460 WYVIE POND DRIVE, SUITE 200  
ACRON, OH 44320  
PH: 419.229.1100  
FAX: 419.229.1105

**OHIO TURNPIKE AND INFRASTRUCTURE COMMISSION**

PORTAGE COUNTY

M.P. 186.0  
M.P. 186.8

PROJECT 43-18-04  
DATE: 10/25/17

2  
113

**OHIO TURNPIKE**

GENERAL SUMMARY

ITEM NO.	TOTAL	UNIT	DESCRIPTION	GENERAL	M.P. 186.0	M.P. 186.8
ROADWAY, CONTINUED						
614	2	EACH	WORK ZONE CROSSOVER LIGHTING SYSTEM		2	
614	1,344	EACH	WORK ZONE RAISED PAVEMENT MARKER			1,344
614	3	EACH	BARRIER REFLECTOR, TYPE 1 (1-WAY)			3
614	4	EACH	BARRIER REFLECTOR, TYPE 2 (1-WAY)			4
614	7	EACH	OBJECT MARKER, ONE WAY			7
614	14	CU. YD.	ASPHALT CONCRETE FOR MAINTAINING TRAFFIC		10	4
614	28	SIGN MONTH	PORTABLE CHANGEABLE MESSAGE SIGN, AS PER PLAN	28		
614	6	SIGN MONTH	DIGITAL SPEED LIMIT (DSL) SIGN ASSEMBLY			6
614	5.69	MILE	WORK ZONE EDGE LINE, CLASS I, 6"			5.69
614	15,211	FOOT	WORK ZONE CHANNELIZING LINE, CLASS I, 12"			15,211
614	1,815	FOOT	WORK ZONE DOTTED LINE, CLASS I			1,815
SP 614C	10.23	MILE	REMOVAL OF PAVEMENT MARKING		10.23	
615	1	LUMP	ROADS FOR MAINTAINING TRAFFIC			LUMP
615	5,162	SQ. YD.	PAVEMENT FOR MAINTAINING TRAFFIC, CLASS A, AS PER PLAN			5,162
616	10	M.GAL.	WATER	10		
617	21,300	SQ. YD.	SHOULDER PREPARATION		21,300	
617	1,800	CU. YD.	COMPACTED AGGREGATE USING SP 304		1,800	
617	50	M.GAL.	WATER		50	
618	0.84	MILE	RUMBLE STRIPS, (ASPHALT CONCRETE)			0.84
621	46	EACH	RPM			46
621	35	EACH	RAISED PAVEMENT MARKER REMOVED			35
SP 621	24	EACH	RAISED PAVEMENT MARKER STIMSONITE MODEL 101LPCR (WHITE)		24	
622	4,260	FOOT	PORTABLE BARRIER, 32", AS PER PLAN			4,260
622	400	FOOT	PORTABLE BARRIER, 32", BRIDGE MOUNTED, AS PER PLAN			400
SP 622	1	LUMP	32" PORTABLE BARRIER (WITHOUT GLARE SCREEN)	1	1	
SP 622	1	LUMP	32" PORTABLE BARRIER (WITH GLARE SCREEN)	1	1	
626	12	EACH	BARRIER REFLECTOR, TYPE 1 (1-WAY)			8
626	12	EACH	BARRIER REFLECTOR, TYPE 2 (1-WAY)		8	4
SP 627	900	CU. YD.	STONE SHOULDER PROTECTION		900	
630	1	EACH	REMOVAL OF GROUND MOUNTED MAJOR SIGN AND REERECTION, AS PER PLAN			1
630	320	SQ. FT.	SIGNING MISC.: ADDITIONAL SIGNS, GROUND MOUNTED, AS DIRECTED BY THE ENGINEER	320		
642	2.56	MILE	EDGE LINE, 6", TYPE 1 (WHITE)		2.56	
642	2.56	MILE	EDGE LINE, 6", TYPE 1 (YELLOW)		2.56	
642	5.12	MILE	LANE LINE, 6", TYPE 1 (WHITE)		5.12	
646	1.78	MILE	EDGE LINE, 6"			1.78
646	0.87	MILE	LANE LINE, 6"			0.87
646	802	FOOT	CHANNELIZING LINE, 12"			802
646	1,893	FOOT	DOTTED LINE, 6"			1,893
646	3.15	MILE	REMOVAL OF PAVEMENT MARKING			3.15
659	17	CU. YD.	TOPSOIL			17
659	150	SQ. YD.	SEEDING AND MULCHING			150
659	8	SQ. YD.	REPAIR SEEDING AND MULCHING			8
659	0.02	TON	COMMERCIAL FERTILIZER			0.02
659	0.03	ACRE	LIME			0.03
659	1	M.GAL.	WATER			1
SPECIAL	1.94	MILE	SONIC NAP ALERT PATTERN (SNAP)		1.94	
SPECIAL	0.21	MILE	RUMBLE STRIP MILL AND FILL			0.21

	<b>GENERAL SUMMARY</b> PORTAGE COUNTY	PROJECT 43-18-04 DATE: 10/25/17	M.P. 186.0 M.P. 186.8	DESIGN AGENCY PALMER ENGINEERING 460 WYVIE POND DRIVE, SUITE 200 AKRON, OH 44320 (330) 475-1100 WWW.PALMERENGINEERING.COM
NO. 1 2	REVISIONS ADDENDUM 1 ADDENDUM 2	CHECKED MAM IN CHARGE MAM	BY DATE DAM 01/18 TES 01/18	DESIGNED DMITS DRAWN TES



GENERAL SUMMARY						
ITEM NO.	TOTAL	UNIT	DESCRIPTION	GENERAL	M.P. 186.0	M.P. 186.8
STRUCTURES						
SP 202	1	LUMP	PORTIONS OF STRUCTURE REMOVED	1		
509	300	POUND	REINFORCING STEEL, REPLACEMENT OF EXISTING REINFORCING STEEL		160	140
SP 509	310,227	POUND	EPOXY COATED REINFORCING STEEL, GRADE 60		155,542	154,685
510	66	EACH	DOWEL HOLES WITH NONSHRINK, NONMETALLIC GROUT			66
SP 511B	928	CU. YD.	CLASS HP4 CONCRETE, SUPERSTRUCTURE DECK SLAB		472	456
SP 511B	170	CU. YD.	CLASS S CONCRETE, BARRIERS AND PARAPETS, USING TYPE 1 CEMENT		89	81
SP 511B	109	CU. YD.	CLASS HP4 CONCRETE, ABUTMENT SLABS		109	
SP 511B	12	CU. YD.	CLASS HP4 CONCRETE, FOR PREPLACEMENT TESTING		6	6
511	10	CU. YD.	CLASS QC1 CONCRETE, ABUTMENT			10
513	9,384	EACH	WELDED STUD SHEAR CONNECTORS		7,200	2,184
513	1	LUMP	STRUCTURAL STEEL, MISC.: COVER PLATE FATIGUE RETROFIT		1	
513	1	LUMP	STRUCTURAL STEEL, MISC.: END DIAPHRAGM MODIFICATION		1	
SP 516A	97	FOOT	CRACK REPAIR USING EPOXY INJECTION		7	90
SP 516B	1,555	FOOT	SEALING OF CONSTRUCTION JOINTS		508	1,047
SP 516G	36	EACH	REPLACE EXPANSION BEARING DEVICE		36	
SP 519	719	SQ. FT.	PATCHING OF CONCRETE STRUCTURES		689	30
SP 527	1	LUMP	FALSEWORK, TEMPORARY BRACING AND PROTECTIVE STRUCTURES	1		
SP 533	256	FOOT	3" CONTINUOUS STRIP SEAL IN STRUCTURAL STEEL JOINT		256	
SP 533	142	FOOT	4" CONTINUOUS STRIP SEAL IN STRUCTURAL STEEL JOINT			142
SP 536	4,467	SQ. YD.	CONCRETE WEATHERPROOFING, DECK, ABUTMENT SLABS, AND APPROACH SLABS		2,510	1,957
SP 536	2,358	SQ. YD.	CONCRETE WEATHERPROOFING, SUBSTRUCTURE		1,688	670
SP 607	322	FOOT	TYPE II FENCE, ALL ALUMINUM (6'-0" CHAIN LINK WITH SPECIALS)			322

3A  
113

PROJECT 43-18-04  
DATE: 10/25/17

M.P. 186.0  
M.P. 186.8

GENERAL SUMMARY

PORTAGE COUNTY

DESIGNED  
DMITS  
DRAWN  
TES

CHECKED  
MAM  
IN CHARGE  
MAM

NO.  
2

REVISIONS  
ADDENDUM 2

BY DATE  
TES 01/18

DESIGN AGENCY  
**Palmer Engineering**  
PALMER ENGINEERING  
460 WYVIE FORD DRIVE, SUITE 300  
AKRON, OH 44320  
CINCINNATI # 513.761.1414  
COLUMBUS # 614.881.1414



OHIO TURNPIKE AND INFRASTRUCTURE COMMISSION



H. PORTABLE BARRIERS

ALL PORTABLE BARRIERS SHOWN ON THE PLANS FOR MAINLINE TEMPORARY TRAFFIC CONTROL WILL BE AS PER ITEM SP 622, INCLUDING TYPE AND INSTALLATION OF GLARE SCREENS AND BARRIER DELINEATORS. SEE OTIC STANDARD DRAWINGS TCR-4, TCR-7 AND TCR-14 FOR ADDITIONAL BARRIER DELINEATOR DETAILS AND PLACEMENT REQUIREMENTS. THE SAME BARRIER CAN BE USED FOR THE VARIOUS PHASES. THE COST FOR TRANSPORTING, INSTALLING, MAINTAINING, REMOVING, STORING AND RE-SETTING THE PORTABLE BARRIER FOR EACH PHASE SHALL BE INCLUDED IN THE ORIGINAL UNIT COST OF SUPPLYING THE BARRIER FOR ITEM SP 622.

ALL COSTS ASSOCIATED BARRIER DELINEATORS AND GLARE SCREENS, INCLUDING TRANSPORTING, INSTALLING, MAINTAINING, REMOVING, STORING AND RE-SETTING THROUGHOUT THE CONTRACT SHALL ALSO BE INCLUDED IN THE ORIGINAL UNIT COST OF SUPPLYING THE BARRIER FOR ITEM SP 622.

THE CONTRACTOR SHALL REPLACE ANY DAMAGED PORTABLE BARRIER WITHIN 24 HOURS OF A DAMAGING IMPACT.

I. WORK ZONE DELINEATION

WORK ZONE DELINEATION WILL BE REQUIRED FOR THE PHASE 2 AND PHASE 3 CROSSOVERS AND SHIFTS AND SHALL BE IN ACCORDANCE WITH PERTINENT SECTIONS OF THE OMUTCD, THE STANDARD CONSTRUCTION DRAWINGS AND ODOT CMS SECTION 621. WORK ZONE RAISED PAVEMENT MARKERS WILL BE REQUIRED FOR THE CROSSOVERS. THE REQUIREMENTS, LAYOUT AND SPACING OF THE WORK ZONE RAISED PAVEMENT MARKERS SHALL BE IN ACCORDANCE WITH ODOT STANDARD CONSTRUCTION DRAWING MT-99.30. CONSTRUCTION ZONE MARKERS WILL BE REQUIRED FOR THE SHIFTS. THE REQUIREMENTS, LAYOUT AND SPACING OF THE CONSTRUCTION ZONE MARKERS SHALL BE IN ACCORDANCE WITH OTIC STANDARD DRAWING TCR-12.1. PAYMENT FOR ALL WORK ASSOCIATED WITH WORK ZONE RAISED PAVEMENT MARKERS AND CONSTRUCTION ZONE MARKERS SHALL BE INCLUDED IN THE LUMP SUM PRICE BID FOR ITEM SP 614, MAINTAINING TRAFFIC.

J. PAYMENT

ALL WORK AND TRAFFIC CONTROL DEVICES SHALL BE IN ACCORDANCE WITH SP 614 AND APPLICABLE PORTIONS OF THE OTIC STANDARD DRAWINGS, ODOT STANDARD CONSTRUCTION DRAWINGS, ODOT CONSTRUCTION & MATERIAL SPECIFICATION (C&MS) AND OTHER APPLICABLE PORTIONS OF THE SPECIFICATIONS, AS WELL AS THE OMUTCD. PAYMENT FOR ALL LABOR, EQUIPMENT AND MATERIALS SHALL BE INCLUDED IN THE LUMP SUM CONTRACT PRICE FOR SP 614 MAINTAINING TRAFFIC, UNLESS SEPARATELY ITEMIZED IN THE PLAN.

ITEM 614, ASPHALT CONCRETE FOR MAINTAINING TRAFFIC

THIS ITEM SHALL BE USED TO INSTALL AND REMOVE TEMPORARY ASPHALT RAMPS/OVERLAYS AT BUTT JOINTS, ALONG THE INSIDE MEDIAN SHOULDERS AND DRAINAGE/UTILITY CASTINGS WHERE REQUIRED. MATERIAL SHALL BE REMOVED PRIOR TO THE PLACEMENT OF THE NEXT COURSE OF ASPHALT. THE FOLLOWING ESTIMATED QUANTITY HAS BEEN CARRIED TO THE GENERAL SUMMARY TO ACCOMPLISH THIS ITEM OF WORK.

ITEM 614, ASPHALT CONCRETE FOR MAINTAINING TRAFFIC.... 10 CUBIC YARD

ITEM 614, WORK ZONE CROSSOVER LIGHTING SYSTEM

THIS WORK SHALL CONSIST OF FURNISHING, ERECTING, OPERATING, MAINTAINING AND REMOVING A WORK ZONE LIGHTING SYSTEM FOR A SINGLE CROSSOVER, OR OVERLAPPING A PAIR OF CROSSOVERS. THE SYSTEM SHALL BE AS SHOWN ON ODOT SCD MT-100.00. THE CONTRACTOR SHALL ARRANGE FOR AND PAY FOR POWER. ALL MATERIALS AND CONSTRUCTION SHALL COMPLY WITH APPLICABLE PORTIONS OF 625 AND 725 EXCEPT: THE PERFORMANCE TEST OF 625.19F, AND CERTIFIED DRAWING REQUIREMENT OF 625.04, ARE WAIVED AND USED MATERIALS IN GOOD CONDITION ARE ACCEPTABLE.

WHENEVER CROSSOVERS ARE USED FOR MAINTAINING TRAFFIC, THE CONTRACTOR SHALL MAINTAIN OHIO TURNPIKE AND INFRASTRUCTURE COMMISSION STANDARD CLEARANCES. POLES WHICH ARE NOT PROTECTED BY GUARDRAIL OR PORTABLE BARRIER SHALL BE LOCATED OUTSIDE THE CLEAR ZONE, AND SHOULD BE LOCATED AT LEAST 30 FT (PREFERABLY 40 FEET) FROM THE EDGE OF PAVEMENT. ADDITIONAL POLE LINES, CABLES AND APPURTENANCES NECESSARY TO FURNISH POWER TO THE LIGHTING SYSTEM SHALL BE INCLUDED IN THIS ITEM. SERVICE POLES SHALL BE POSITIONED WITH THE SAME CONSTRAINTS AS THE LIGHTING POLES AS A MINIMUM.

PAYMENT WILL BE MADE AT THE UNIT PRICE PER EACH FOR ITEM 614, WORK ZONE CROSSOVER LIGHTING SYSTEM THROUGHOUT ALL PHASES OF WORK WHEN THE CROSSOVER ROADWAYS ARE USED.

THE FOLLOWING QUANTITY HAS BEEN CARRIED TO THE GENERAL SUMMARY: 2 EACH

ITEM SPECIAL, FILL AND PLUG EXISTING CONDUIT

THIS ITEM SHALL CONSIST OF THE CONSTRUCTION OF BULKHEADS IN TEMPORARY 12 INCH DIAMETER CONDUIT AND FILLING THE AREA THUS SEALED OFF WITH ITEM 613, SAND OR OTHER MATERIAL APPROVED BY THE ENGINEER.

BULKHEADS SHALL BE LOCATED AT THE LIMITS OF THE AREA TO BE FILLED AS INDICATED ON THE PLANS. THE BULKHEADS SHALL CONSIST OF BRICK OR CONCRETE MASONRY WITH A MINIMUM THICKNESS OF 12 INCHES.

THE FILL MATERIAL SHALL BE PUMPED INTO PLACE, OR PLACED BY OTHER MEANS APPROVED BY THE ENGINEER, SO THAT, AFTER SETTLEMENT, AT LEAST 90 PERCENT OF THE CROSS-SECTIONAL AREA OF THE CONDUIT, FOR ITS ENTIRE LENGTH, SHALL BE FILLED.

PAYMENT FOR ITEM SPECIAL, FILL AND PLUG EXISTING CONDUIT SHALL BE INCLUDED IN THE LUMP SUM BID FOR ITEM SP 614, MAINTAINING TRAFFIC.

DRAINAGE ITEMS FOR MAINTENANCE OF TRAFFIC

PAYMENT FOR ALL WORK ASSOCIATED WITH DRAINAGE ITEMS (TEMPORARY AND TO REMAIN) DETAILED ON THE MAINTENANCE OF TRAFFIC TEMPORARY DRAINAGE DETAILS SHEETS SHALL BE INCLUDED IN THE LUMP SUM BID FOR ITEM SP 614, MAINTAINING TRAFFIC.

ITEM 622 - CONCRETE BARRIER, TYPE B-50, AS PER PLAN

ITEM 622 - CONCRETE BARRIER, TYPE B-50, AS PER PLAN SHALL HAVE A NEW JERSEY STYLE FACE AND SHALL BE CONSTRUCTED IN ACCORDANCE WITH OTIC STANDARD DRAWING CBR-1 AND SECTION 622 OF THE SPECIFICATIONS.

PAYMENT FOR ALL MATERIALS AND LABOR SHALL BE INCLUDED IN THE LUMP SUM PRICE BID FOR ITEM SP 614, MAINTAINING TRAFFIC. SEE SHEET 13 FOR DETAILS.

ITEM 614, MAINTAINING TRAFFIC

MAINTENANCE OF TRAFFIC SEQUENCE: M.P. 186.8 MAINTENANCE OF TRAFFIC PLANS ARE BASED ON THE FOLLOWING SUGGESTED SEQUENCE OF CONSTRUCTION:

A MINIMUM OF 2 LANE(S) OF TRAFFIC IN EACH DIRECTION SHALL BE MAINTAINED AT ALL TIMES BY USE OF THE EXISTING PAVEMENT, THE COMPLETED PAVEMENT, COMPLETED BRIDGE, ITEM 615 PAVEMENT FOR MAINTAINING TRAFFIC AND ITEM 615 ROADS FOR MAINTAINING TRAFFIC.

PHASE 1

THIS PHASE WILL CONSIST OF RECONSTRUCTING THE MEDIAN SHOULDERS TO BE USED TO MAINTAIN TRAFFIC DURING PHASE 2 AND RECONSTRUCTING AND WIDENING OF THE OUTSIDE SHOULDERS TO BE USED TO MAINTAIN TRAFFIC DURING PHASE 3 (SEE MAINTENANCE OF TRAFFIC PLANS FOR LOCATIONS). THE INTENT IS TO REBUILD AND WIDEN THE OUTSIDE SHOULDERS UP TO THE FULL DEPTH PAVEMENT AND WIDENING LIMITS ASSOCIATED WITH THE REAR APPROACH SLAB AND DROP LANE TAPER; AND AHEAD OF THE FULL DEPTH PAVEMENT LIMITS ASSOCIATED WITH THE FORWARD APPROACH SLAB. (SEE ROADWAY AND GEOMETRY PLANS). PERFORM TEMPORARY GRADING AND SEEDING OPERATIONS IN ASSOCIATION WITH THE SHOULDER WIDENING. RELOCATE THE LIGHT POLES AT STATIONS 55+70 AND 59+10. RELOCATE GROUND MOUNTED SIGNS AS REQUIRED. PLACE THE TEMPORARY GUARDRAIL AND RELOCATE THE CANTILEVER SIGN AT BASELINE I-480 EASTBOUND STATION 212+00, RIGHT TO A GROUND MOUNTED LOCATION APPROVED BY THE ENGINEER (SEE MAINTENANCE OF TRAFFIC PLANS - PHASE 3 FOR LOCATIONS).

LANE CLOSURES SHALL ONLY BE PERMITTED FOR PLACEMENT OF THE PORTABLE BARRIER AND SHALL BE PER ODOT STANDARD CONSTRUCTION DRAWING MT-95.30 AND THE PERMITTED LANE CLOSURES FOUND AT: [HTTP://PLCM.DOT.STATE.OH.US/PLCMSEARCH.ASPX](http://plcm.dot.state.oh.us/plcmsearch.aspx). USE ODOT STANDARD CONSTRUCTION DRAWINGS MT-98.10 AND MT-98.20 FOR RAMP SHOULDER AND RIGHT LANE CLOSURES THAT IMPACT THE EASTBOUND ON-RAMP FROM FROST ROAD (T-197) AND THE EASTBOUND OFF-RAMP TO OHIO TURNPIKE TOLL PLAZA GATE 187, RESPECTIVELY.

USE PORTABLE BARRIER AT THE EDGE OF PAVEMENT AS REQUIRED BY ODOT STANDARD CONSTRUCTION DRAWING MT-101.90 UNTIL THE SHOULDER WORK IS COMPLETED. PROVIDE PORTABLE BARRIER ALONG THE OUTSIDE AND MEDIAN EDGE LINES OF THE EASTBOUND LANES, ALTERNATELY. REDUCE LANE WIDTHS TO 11' AND SHIFT AS PER ODOT STANDARD CONSTRUCTION DRAWING MT-102.10.

PHASE 2

THIS PHASE WILL CONSIST OF THE REPLACEMENT OF THE OUTSIDE PORTION OF THE EASTBOUND BRIDGE SUPERSTRUCTURE, APPROACH SLABS AND FULL DEPTH PAVEMENT. THE APPROACH PAVEMENT WIDENING, OUTSIDE SHOULDER CURBING, DRAINAGE, UNDER-DRAINS AND BRIDGE TERMINAL ASSEMBLY AND SHALL ALSO BE CONSTRUCTED DURING THIS PHASE. (SEE ROADWAY AND GEOMETRY PLANS). THE ASPHALT PAVING SHALL BE PERFORMED UP THROUGH THE INTERMEDIATE COURSE.

ASPHALT CONCRETE FOR MAINTAINING TRAFFIC SHALL BE PLACED TO PROVIDE SMOOTH PROFILE TRANSITIONS ALONG THE PORTIONS OF THE EASTBOUND LANES CARRYING TRAFFIC IN SUBSEQUENT PHASES TO THE SATISFACTION OF THE ENGINEER.

PHASE 3

THIS PHASE WILL CONSIST OF THE REPLACEMENT OF THE MEDIAN SIDE PORTION OF THE EASTBOUND BRIDGE SUPERSTRUCTURE, APPROACH SLABS, FULL DEPTH PAVEMENT AND UNDER-DRAINS. (SEE ROADWAY AND GEOMETRY PLANS). THE ASPHALT PAVING SHALL BE PERFORMED UP THROUGH THE INTERMEDIATE COURSE.

ASPHALT CONCRETE FOR MAINTAINING TRAFFIC SHALL BE PLACED TO PROVIDE SMOOTH PROFILE TRANSITIONS ALONG THE PORTIONS OF THE EASTBOUND LANES CARRYING TRAFFIC IN SUBSEQUENT PHASES TO THE SATISFACTION OF THE ENGINEER.

PHASE 4

REMOVE THE PORTION OF THE SHOULDER WIDENING THAT IS OUTSIDE THE LIMITS OF THE PERMANENT SHOULDER WIDTH BY SAWCUTTING ALONG A LINE 10 FEET OFF THE EXISTING EDGE LINE. A RESULTANT 10'-0" WIDE FULL DEPTH SHOULDER SHALL BE LEFT IN PLACE. REGRADE THE AREAS ADJACENT TO THE TEMPORARY SHOULDER WIDENING TO THEIR ORIGINAL CROSS SECTION AND RESTORE THE RELOCATED LIGHT POLES AND SIGNS TO THEIR ORIGINAL LOCATIONS. COMPLETE THE PAVEMENT PLANING AND SURFACE COURSE ASPHALT ON THE APPROACH PAVEMENT. RE-ERECT THE CANTILEVER SIGN ON A NEW FOUNDATION, PAVE UNDER GUARDRAIL, SET THE REMAINDER OF THE PERMANENT GUARDRAIL, PLACE PAVEMENT MARKINGS, SHOULDER RUMBLE STRIPS AND OTHER INCIDENTAL WORK NOT CONSTRUCTED IN PREVIOUS PHASES. LANE CLOSURES SHALL BE PER SCD MT-95.30 AND THE PERMITTED LANE CLOSURE NOTE, THIS SHEET.

ALL WORK SHALL BE COMPLETED TO THE SATISFACTION OF THE CHIEF ENGINEER; AND ALL LANES SHALL BE OPEN TO TRAFFIC IN THE PROPOSED ALIGNMENT PRIOR TO THE END OF CONSTRUCTION SEASON ONE, AS DESCRIBED IN THE WINTER LIMITATIONS NOTE ON SHEET 8.

NO WORK SHALL BE PERFORMED AND ALL EXISTING LANES SHALL BE OPEN TO TRAFFIC DURING THE FOLLOWING DESIGNATED HOLIDAYS OR EVENTS:

Table with 2 columns: HOLIDAY OR EVENT, TIME ALL LANES MUST BE OPEN TO TRAFFIC. Rows include CHRISTMAS, NEW YEARS, MEMORIAL DAY, FOURTH OF JULY, LABOR DAY, THANKSGIVING.

THE PERIOD OF TIME THAT THE LANES ARE TO BE OPEN DEPENDS ON THE DAY OF THE WEEK ON WHICH THE HOLIDAY OR EVENT FALLS. THE FOLLOWING SCHEDULE SHALL BE USED TO DETERMINE THIS PERIOD:

Table with 2 columns: DAY OF HOLIDAY OR EVENT, TIME ALL LANES MUST BE OPEN TO TRAFFIC. Rows include SUNDAY, MONDAY, TUESDAY, WEDNESDAY, THURSDAY, FRIDAY, SATURDAY with corresponding time ranges.

IN ADDITION, THE DURATION OF TIME THAT THE WIDTH OF THE EASTBOUND TRAVEL LANES ARE REDUCED TO 10'-6" SHALL BE RESTRICTED TO 120 CALENDAR DAYS PER PHASE.

SHOULD THE CONTRACTOR FAIL TO MEET ANY OF THESE REQUIREMENTS, THE CONTRACTOR SHALL BE ASSESSED A DISINCENTIVE IN THE AMOUNT OF \$50 FOR EACH MINUTE THAT THE ABOVE DESCRIBED LANE CLOSURE RESTRICTIONS ARE VIOLATED.

LENGTH AND DURATION OF LANE CLOSURES AND RESTRICTIONS SHALL BE AT THE APPROVAL OF THE ENGINEER. IT IS THE INTENT TO MINIMIZE THE IMPACT TO THE TRAVELING PUBLIC. LANE CLOSURES OR RESTRICTIONS OVER SEGMENTS OF THE PROJECT IN WHICH NO WORK IS ANTICIPATED WITHIN A REASONABLE TIME FRAME, AS DETERMINED BY THE ENGINEER, SHALL NOT BE PERMITTED. THE LEVEL OF UTILIZATION OF MAINTENANCE OF TRAFFIC DEVICES SHALL BE COMMENSURATE WITH THE WORK IN PROGRESS.

ALL WORK AND TRAFFIC CONTROL DEVICES SHALL BE IN ACCORDANCE WITH C&MS 614 AND OTHER APPLICABLE PORTIONS OF THE SPECIFICATIONS, AS WELL AS THE OHIO MANUAL OF UNIFORM TRAFFIC CONTROL DEVICES. PAYMENT FOR ALL LABOR, EQUIPMENT AND MATERIALS SHALL BE INCLUDED IN THE LUMP SUM CONTRACT PRICE FOR ITEM 614, MAINTAINING TRAFFIC, UNLESS SEPARATELY ITEMIZED IN THE PLAN.

PERMITTED LANE CLOSURE TIMES

IN ORDER TO COMPLY WITH ODOT REQUIREMENTS FOR TRAFFIC CONGESTION ON INTERSTATE ROUTES WITHIN OHIO, THE PLCM DEFINES WORK HOURS THAT PERMIT LANE RESTRICTIONS ON THE INTERSTATE ROUTES IN OHIO. THE DISTRICT LANE RESTRICTIONS TABLE AND THE PERMITTED LANE CLOSURES FOUND AT: [HTTP://PLCM.DOT.STATE.OH.US/PLCMSEARCH.ASPX](http://plcm.dot.state.oh.us/plcmsearch.aspx) WILL BE STRICTLY ENFORCED BY ODOT AND THE OHIO TURNPIKE AND INFRASTRUCTURE COMMISSION.

SHOULD THE CONTRACTOR FAIL TO MEET ANY OF THESE REQUIREMENTS, THE CONTRACTOR SHALL BE ASSESSED A DISINCENTIVE IN THE AMOUNT OF \$50 FOR EACH MINUTE THAT THE REQUIREMENTS ARE VIOLATED.

INTERIM MAINTENANCE OF TRAFFIC PHASES AND OPERATIONS

THE DETAILED MAINTENANCE OF TRAFFIC PLANS PRESENTED ON THE FOLLOWING SHEETS REFLECT MAJOR PHASES OF CONSTRUCTION REQUIRED TO COMPLETE THE PROJECT. QUANTITIES FOR ITEMS PAID SEPARATELY FOR THESE MAJOR PHASES ARE INCLUDED IN THE PLANS.

THE CONTRACTOR WILL BE REQUIRED TO PERFORM WORK IN ORDER TO ESTABLISH OR TRANSITION INTO THESE MAJOR PHASES. THIS WORK SHALL BE CONSIDERED IN INTERIM MAINTENANCE OF TRAFFIC PHASES. THE CONTRACTOR SHALL BE RESPONSIBLE FOR ALL LABOR, MATERIALS, EQUIPMENT AND TRAFFIC CONTROL DEVICES REQUIRED TO ESTABLISH AND REMOVE THE MAJOR PHASES OF CONSTRUCTION.

PAYMENT FOR THE WORK DESCRIBED ABOVE FOR THE INTERIM MAINTENANCE OF TRAFFIC PHASES SHALL BE INCLUDED IN THE LUMP SUM UNIT PRICE FOR ITEM 614, MAINTAINING TRAFFIC AND SHALL INCLUDE ALL REQUIRED LABOR, EQUIPMENT, MATERIALS AND INCIDENTALS.

711609\_1480\_MN001.dwg: 1/20/18 - 6:59pm

Project information sidebar including PROJECT 43-18-04, DATE: 10/25/17, M.P. 186.0 AND M.P. 186.8, PORTAGE COUNTY, OHIO TURNPIKE AND INFRASTRUCTURE COMMISSION, DESIGN AGENCY: PALMER ENGINEERING, and revision table.

**MAINTAINING TRAFFIC**

GENERALLY, THE CONTRACTOR SHALL CONDUCT OPERATIONS AS TO COMPLETE THE PROPOSED IMPROVEMENT WITH A MINIMUM OF HAZARD, DELAY AND INCONVENIENCE TO THE MOTORISTS USING THE HIGHWAY AFFECTED BY THE WORK DONE UNDER THIS CONTRACT.

THE CONTRACTOR'S RESPONSIBILITY TO THE SAFETY OF THE MOTORING PUBLIC WHILE PERFORMING THE REQUIREMENTS OF THE CONTRACT SHALL BE IN ACCORDANCE WITH THESE TEMPORARY TRAFFIC CONTROL PLANS, THE SPECIFICATIONS AND SPECIAL PROVISIONS, THE CURRENT EDITION, LATEST REVISION OF THE "OHIO MANUAL OF UNIFORM TRAFFIC CONTROL DEVICES" (OMUTCD) AND "TEMPORARY TRAFFIC CONTROL ON THE TURNPIKE," LATEST REVISION. IN ADDITION TO THE CONSTRUCTION AND MATERIAL SPECIFICATIONS, THE CONTRACTOR SHALL FURNISH, ERECT, MAINTAIN AND SUBSEQUENTLY REMOVE ALL TRAFFIC CONTROL DEVICES AS PER SP 614 MAINTAINING TRAFFIC, INCLUDING BARRICADES AND SIGNS IN ACCORDANCE WITH THE OHIO DEPARTMENT OF TRANSPORTATION (ODOT) STANDARD CONSTRUCTION DRAWINGS AND THE OMUTCD.

IN ADDITION, THE FOLLOWING SPECIFIC PROVISIONS ARE MANDATORY:

**I. NOTIFICATION OF TRAFFIC RESTRICTIONS**

THROUGHOUT THE DURATION OF THE PROJECT, THE CONTRACTOR SHALL NOTIFY THE PROJECT ENGINEER IN WRITING OF ALL TRAFFIC RESTRICTIONS AND UPCOMING MAINTENANCE OF TRAFFIC CHANGES. THE CONTRACTOR SHALL ENSURE THE WRITTEN NOTIFICATION IS SUBMITTED IN A TIMELY MANNER TO ALLOW THE PROJECT ENGINEER TO MEET THE REQUIRED TIME FRAMES SET FORTH IN THE TABLE BELOW TO INFORM THE SPECIAL HAULING PERMITS SECTION (HAULING.PERMITS@dot.ohio.gov) AND THE DISTRICT PUBLIC INFORMATION OFFICE (PIO). THIS NOTIFICATION SHALL BE RECEIVED BY THE PROJECT ENGINEER PRIOR TO THE PHYSICAL SETUP OF ANY APPLICABLE SIGNS OR MESSAGE BOARDS.

INFORMATION SHOULD INCLUDE, BUT IS NOT LIMITED TO, ALL CONSTRUCTION ACTIVITIES THAT IMPACT OR INTERFERE WITH TRAFFIC AND SHALL LIST THE SPECIFIC LOCATION, TYPE OF WORK, ROAD STATUS, DATE AND TIME OF RESTRICTION, DURATION OF RESTRICTION, NUMBER OF LANES MAINTAINED, NUMBER OF LANES CLOSED, MINIMUM VERTICAL CLEARANCE, MINIMUM WIDTH OF DRIVABLE PAVEMENT, DETOUR ROUTES, IF APPLICABLE, AND ANY OTHER INFORMATION REQUESTED BY THE PROJECT ENGINEER.

**NOTIFICATION TIME TABLE**

ITEM	DURATION OF CLOSURE	NOTICE DUE TO PERMITS AND PIO
RAMP AND ROAD CLOSURES	> = 2 WEEKS.....	21 CALENDAR DAYS PRIOR TO CLOSURE
	> 12 HOURS AND < 2 WEEKS.....	14 CALENDAR DAYS PRIOR TO CLOSURE
	< = 12 HOURS.....	4 BUSINESS DAYS PRIOR TO CLOSURE
LANE CLOSURE AND RESTRICTIONS	> = 2 WEEKS.....	14 CALENDAR DAYS PRIOR TO CLOSURE
	< 2 WEEKS.....	5 BUSINESS DAYS PRIOR TO CLOSURE
START OF CONSTRUCTION AND TRAFFIC PATTERN CHANGES	N/A.....	14 CALENDAR DAYS PRIOR TO IMPLEMENTATION

ANY UNFORESEEN CONDITIONS NOT SPECIFIED IN THE PLANS REQUIRING TRAFFIC RESTRICTIONS SHALL ALSO BE REPORTED TO THE PROJECT ENGINEER USING THE NOTIFICATION TIME TABLE.

**II. MAINTENANCE OF TRAFFIC SYSTEMS**

**A. WHEN REQUIRED**

WHENEVER ANY PART OF THE TRAVELED SURFACE IS BEING WORKED UPON OR IS OTHERWISE NOT SUITABLE FOR SAFE AND CONVENIENT USE BY VEHICLES, TRAFFIC CONTROL DEVICES SUFFICIENT TO PROTECT SUCH AREAS TO ASSURE THE SAFE AND CONVENIENT PASSAGE OF VEHICULAR TRAFFIC SHALL BE INSTALLED AND MAINTAINED. SUCH TRAFFIC CONTROL DEVICES AND THE MANNER IN WHICH THEY ARE USED SHALL BE CONSISTENT WITH THESE PLANS AND THE OMUTCD. THE TRAFFIC CONTROL DEVICE SYSTEM SHALL CONSTITUTE THE MINIMUM PROVISIONS FOR TRAFFIC CONTROL FOR EACH PARTICULAR SITUATION. WHENEVER THE ENGINEER DEEMS IT NECESSARY ESPECIALLY WHERE A GRADE, CURVE, OR MERGE CONDITIONS EXISTS, HE/SHE MAY DIRECT THAT ADDITIONAL OR ALTERNATIVE DEVICES BE USED.

**B. CONDITIONS**

DURING ALL PARTS OF THIS PROJECT, FLAGGERS, SIGNING, BARRICADES, FLASHING ARROWS, ETC. SHALL BE LOCATED AS INDICATED IN THE OMUTCD OR AS SHOWN IN THE STANDARD CONSTRUCTION DRAWINGS. TWO-WAY TRAFFIC SHALL BE MAINTAINED AT ALL TIMES.

**C. ADVANCE WARNING SIGNS**

ALL ADVANCE WARNING SIGNS FOR ANY CONDITION WHICH RESTRICTS TRAFFIC SHALL BE ERECTED BEFORE ANY SUCH RESTRICTION IS PUT INTO EFFECT. ALL SUCH SIGNS SHALL BE COVERED OR REMOVED FROM THE VIEW OF TRAFFIC WHENEVER THEY ARE NOT APPLICABLE.

**D. FLAGGERS**

THE CONTRACTOR SHALL FURNISH ADDITIONAL FLAGGERS AS DIRECTED BY THE ENGINEER.

**E. MAINTENANCE OF TRAFFIC CONTROL ZONES**

THE CONTRACTOR SHALL BE RESPONSIBLE TO MAINTAIN THE SIGNS, DRUMS AND TEMPORARY PAVEMENT MARKINGS AT THE LOCATIONS DETAILED IN THE PLANS OR SPECIFIED IN THE STANDARD DRAWINGS. THE CONTRACTOR SHALL IMMEDIATELY CORRECT ANY DEFICIENCY IN TRAFFIC ZONE ALIGNMENT, EQUIPMENT, NUMBER OF DEVICES OR PROCEDURE OF FLAG PERSONS WHICH IS BROUGHT TO HIS/HER ATTENTION BY THE ENGINEER.

**F. FAILURE TO COMPLY**

IF THERE IS ANY FAILURE TO COMPLY WITH PROVISIONS FOR TRAFFIC CONTROL SET OUT IN THESE PLANS AND NOTES, OR WITH THE PROVISIONS OF THE OMUTCD, THE HIGHWAY IN THE VICINITY OF THE WORK AREA SHALL NOT BE CONSIDERED IN A CONDITION FOR THE SAFE AND CONVENIENT USE BY THE TRAVELING PUBLIC. ANY FAILURE TO KEEP THE HIGHWAY IN THE VICINITY OF THE WORK AREA, IN A CONDITION FOR THE SAFE AND CONVENIENT USE BY THE TRAVELING PUBLIC SHALL BE CONSIDERED A BREACH OF THIS CONTRACT. WORK SHALL BE SUSPENDED UNTIL THE CONTRACTOR COMPLIES WITH THE PROVISIONS OF THE AFOREMENTIONED ITEMS.

**III. MAINTENANCE OF TRAFFIC MATERIALS**

**A. SIGNS**

SIGN DIMENSIONS AND SPECIFICATIONS, INCLUDING LETTER SIZES SHALL BE AS SHOWN ON THE PLANS, PROVIDED IN THE OMUTCD, AND/OR THE STANDARD CONSTRUCTION DRAWINGS. THE SIGNS SHALL BE SUBJECT TO APPROVAL OF THE ENGINEER PRIOR TO THE START OF THE PROJECT. SEE C&MS 614.04 FOR ADDITIONAL SIGNING REQUIREMENTS.

**B. SIGN SUPPORTS**

SIGN SUPPORTS SHALL BE OF SUFFICIENT SIZE AND HEIGHT AS TO SUPPORT THE SIGNS AT THE APPROPRIATE HEIGHT. SUPPORTS SHALL BE ADEQUATE IN MASS AND STABILITY TO PREVENT THE SIGNS FROM BEING BLOWN OVER BY WIND OR VEHICULAR GENERATED AIR TURBULENCE.

**C. WORK ZONE PAVEMENT MARKINGS**

THE WORK ZONE PAVEMENT MARKINGS SHALL BE PER C&MS 614.11. THE WIDTH OF THE WORK ZONE PAVEMENT MARKINGS SHALL BE AS NOTED ON THE PLANS. REMOVAL OF PAVEMENT MARKINGS SHALL BE PER THE STANDARD CONSTRUCTION DRAWINGS AND C&MS 614.11(G) FOR EXISTING PAVEMENT MARKINGS THAT WERE PRESENT PRIOR TO THE START OF CONSTRUCTION AND FOR REMOVAL OF WORK ZONE PAVEMENT MARKINGS THAT CONFLICT WITH THE WORK ZONE PAVEMENT FOR EACH PHASE.

**D. WORK ZONE GUARDRAIL CONSTRUCTION**

THE GUARDRAIL SHALL BE TYPE MGS AS SPECIFIED IN ACCORDANCE WITH ITEM 606 AND APPLICABLE ODOT STANDARD CONSTRUCTION DRAWINGS, EXCEPT THAT USED MATERIAL IN GOOD CONDITION WILL BE PERMITTED.

**E. GUARDRAIL DELINEATION**

BARRIER REFLECTORS SHALL BE INSTALLED ON ALL TEMPORARY GUARDRAIL USED FOR TRAFFIC CONTROL AND ON ALL PERMANENT GUARDRAIL LOCATED WITHIN 5 FEET OF THE EDGE OF THE ADJACENT TRAVEL LANE. BARRIER REFLECTORS SHALL CONFORM TO C&MS 626.

OBJECT MARKERS SHALL BE INSTALLED ON ALL TEMPORARY AND PERMANENT GUARDRAIL LOCATED WITHIN 5 FEET OF THE EDGE OF THE ADJACENT TRAVEL LANE. GUARDRAIL-MOUNTING OF OBJECT MARKERS SHALL BE MADE BY INSTALLING THE OBJECT MARKERS ON THE EXTENSION BLOCKS RATHER THAN DIRECTLY ONTO THE GUARDRAIL ITSELF. OBJECT MARKERS SHALL CONFORM TO C&MS 614.03 AND THE SPACING SHALL BE APPROXIMATELY 50 FEET.

**F. DRUMS**

DRUMS SHALL BE IN ACCORDANCE WITH PERTINENT SECTIONS OF THE OMUTCD AND THE STANDARD CONSTRUCTION DRAWINGS. SPACING SHALL BE AS SHOWN ON THE PLANS. IN ADDITION TO THE REQUIREMENTS OF THE PLANS, SPECIFICATIONS AND PROPOSAL, DRUMS FURNISHED BY THE CONTRACTOR SHALL BE NEW AND UNUSED AT THE TIME OF ARRIVAL ON THE PROJECT. ANY DRUMS BROUGHT ON THE PROJECT, WHICH HAVE PREVIOUSLY BEEN USED ELSEWHERE, WILL NOT BE ACCEPTED. PAYMENT FOR DRUMS SHALL BE INCLUDED IN THE LUMP SUM PRICE BID FOR ITEM 614, MAINTAINING TRAFFIC.

**G. FLASHERS (TYPE A WARNING LIGHTS)**

TYPE A WARNING LIGHTS SHALL BE PLACED ON ALL SIGNS AT ALL TIMES AS REQUIRED BY THE PLANS, OMUTCD AND THE STANDARD CONSTRUCTION DRAWINGS.

**H. PORTABLE BARRIERS**

ALL PORTABLE BARRIERS SHOWN ON THE PLANS FOR MAINTAINING TRAFFIC (TEMPORARY TRAFFIC CONTROL) WILL BE AS PER ITEM 622, PORTABLE BARRIER, 32", AS PER PLAN AND ITEM 622, PORTABLE BARRIER, 32", BRIDGE MOUNTED, AS PER PLAN. THE SAME BARRIER CAN BE USED FOR THE VARIOUS PHASES. THE COST FOR TRANSPORTING, INSTALLING, MAINTAINING, REMOVING, STORING AND RE-SETTING THE PORTABLE BARRIER FOR EACH PHASE SHALL BE INCLUDED IN THE ORIGINAL UNIT COST OF SUPPLYING THE BARRIER FOR ITEM 622.

THE CONTRACTOR SHALL REPLACE ANY DAMAGED TEMPORARY PORTABLE BARRIER WITHIN 24 HOURS OF A DAMAGING IMPACT.

INCREASED BARRIER DELINEATION SHALL CONSIST OF BARRIER REFLECTORS AND OBJECT MARKERS WHICH SHALL BE INSTALLED ON ALL PORTABLE BARRIER (PB) USED FOR TRAFFIC CONTROL AND ON PERMANENT CONCRETE BARRIER (INCLUDING BRIDGE PARAPETS) LOCATED WITHIN 5 FEET OF THE EDGE OF THE ADJACENT TRAVEL LANE.

BARRIER REFLECTORS SHALL CONFORM TO C&MS 626, EXCEPT THAT THE SPACING SHALL BE AS PER TRAFFIC STANDARD CONSTRUCTION DRAWING MT-101.70. OBJECT MARKERS AND THEIR INSTALLATION SHALL CONFORM TO C&MS 614.03 AND SCD MT-101.70.

INCREASED BARRIER DELINEATION, AS SPECIFIED HEREIN, SHALL BE INSTALLED ON ALL PB AND CONCRETE PERMANENT BARRIER LOCATED WITHIN 5 FEET OF THE EDGE OF THE TRAVELED LANE ALONG TAPERS AND TRANSITION AREAS AND ALONG CURVES (OUTSIDE ONLY) WITH DEGREE OF CURVATURE GREATER THAN OR EQUAL TO 3 DEGREES.

THE INCREASED BARRIER DELINEATION SHALL CONSIST OF EITHER DELINEATION PANELS OR THE TRIPLE STACKING OF WORK ZONE BARRIER REFLECTORS. DELINEATION PANELS SHALL CONSIST OF PANELS OF DELINEATION, APPROXIMATELY 34 INCHES LONG AND 6 INCHES WIDE AND SHALL BE CRIMPED. PANELS SHALL BE INSTALLED AND SPACED PER TRAFFIC SCD MT-101.70.

TRIPLE-STACKED BARRIER REFLECTORS SHALL CONSIST OF ALIGNING THREE BARRIER REFLECTORS VERTICALLY, AT LOCATIONS WHERE A SINGLE BARRIER REFLECTOR WOULD BE OTHERWISE ATTACHED. THERE SHALL BE NO OPEN SPACE BETWEEN THE ADJACENT BARRIER REFLECTORS. THE TRIPLE-STACKED BARRIER REFLECTORS SHALL CONFORM TO C&MS 626, EXCEPT THAT THEY SHALL BE SPACED AND ALIGNED PER TRAFFIC SCD MT-101.70.

ALL COSTS ASSOCIATED BARRIER DELINEATORS, INCLUDING TRANSPORTING, INSTALLING, MAINTAINING, REMOVING, AND STORING THROUGHOUT THE CONTRACT SHALL ALSO BE INCLUDED IN THE ORIGINAL UNIT COST OF SUPPLYING THE BARRIER FOR ITEM 622.

**I. WORK ZONE DELINEATION**

WORK ZONE DELINEATION WILL BE REQUIRED FOR THE PHASE 1,2 AND 3 SHIFTS AND SHALL BE IN ACCORDANCE WITH PERTINENT SECTIONS OF THE OMUTCD, THE STANDARD CONSTRUCTION DRAWINGS AND ODOT C&MS 621. THE REQUIREMENTS, LAYOUT AND SPACING OF THE WORK ZONE RAISED PAVEMENT MARKERS SHALL BE IN ACCORDANCE WITH ODOT STANDARD CONSTRUCTION DRAWING MT-99.30

**J. PAYMENT**

ALL WORK AND TRAFFIC CONTROL DEVICES SHALL BE IN AS DESCRIBED IN THE PLANS, IN ACCORDANCE WITH ITEM 614 AND APPLICABLE PORTIONS OF THE ODOT STANDARD CONSTRUCTION DRAWINGS, ODOT CONSTRUCTION & MATERIAL SPECIFICATIONS (C&MS) AND OTHER APPLICABLE PORTIONS OF THE SPECIFICATIONS, AS WELL AS THE OMUTCD. PAYMENT FOR ALL LABOR, EQUIPMENT AND MATERIALS SHALL BE INCLUDED IN THE LUMP SUM CONTRACT PRICE FOR 614 MAINTAINING TRAFFIC, UNLESS SEPARATELY ITEMIZED IN THE PLAN.

 PALMER ENGINEERING 460 WYVIE POND DRIVE, SUITE 300 AKRON, OH 44320 TELEPHONE: 330.933.1100 FAX: 330.933.1105	DESIGN AGENCY	BY DATE	NO.	CHECKED	DESIGNED	MAINTENANCE OF TRAFFIC GENERAL NOTES PORTAGE COUNTY M.P. 186.8	PROJECT 43-18-04 DATE: 10/25/17	OHIO TURNPIKE 6 113	OHIO TURNPIKE COMMISSION
	REVISIONS	DAM	2	MAM	DAM				
	ADDENDUM 2	01/18		M/CHARGE	TGW				

**ITEM 614, WORK ZONE IMPACT ATTENUATOR FOR 24" WIDE HAZARDS (UNIDIRECTIONAL OR BIDIRECTIONAL)**

THIS ITEM SHALL CONSIST OF FURNISHING AND INSTALLING A NON-GATING IMPACT ATTENUATOR. FURNISH AN IMPACT ATTENUATOR FROM THE OFFICE OF ROADWAY ENGINEERING'S APPROVED LIST FOR WORK ZONE IMPACT ATTENUATORS ON THE ROADWAY STANDARDS WEB PAGE.

INSTALLATION SHALL BE AT THE LOCATIONS SPECIFIED IN THE PLANS IN ACCORDANCE WITH THE MANUFACTURER'S SPECIFICATIONS.

THE CONTRACTOR SHALL REPAIR OR REPLACE A DAMAGED UNIT WITHIN 24 HOURS OF A DAMAGING IMPACT.

WHEN BIDIRECTIONAL DESIGNS ARE SPECIFIED, THE CONTRACTOR SHALL SUPPLY APPROPRIATE TRANSITIONS.

WHEN GATING IMPACT ATTENUATORS ARE DESIRED, THE CONTRACTOR SHALL SUBMIT DOCUMENTATION TO THE ENGINEER FOR ACCEPTANCE.

THE COST FOR THE ADDITIONAL BARRIER REQUIRED FOR A GATING IMPACT ATTENUATOR SHALL BE INCLUDED IN THE COST OF THE GATING IMPACT ATTENUATOR.

PAYMENT FOR THE ABOVE WORK SHALL BE MADE AT THE UNIT PRICE BID AND SHALL INCLUDE ALL LABOR, TOOLS, EQUIPMENT AND MATERIALS NECESSARY TO CONSTRUCT AND MAINTAIN A COMPLETE AND FUNCTIONAL IMPACT ATTENUATOR SYSTEM, INCLUDING ALL RELATED BACKUPS, TRANSITIONS, LEVELING PADS, HARDWARE AND GRADING, NOT SEPARATELY SPECIFIED, AS REQUIRED BY THE MANUFACTURER.

**ITEM 614 PORTABLE CHANGEABLE MESSAGE SIGN, AS PER PLAN**  
THE CONTRACTOR SHALL FURNISH, INSTALL, MAINTAIN AND REMOVE, WHEN NO LONGER NEEDED, THREE (3) PORTABLE CHANGEABLE MESSAGE SIGNS (PCMS). THE SIGNS SHALL BE LOCATED NEAR THE PROJECT SITES, ONE FOR EACH DIRECTION OF TRAVEL APPROACHING AN ACTIVE WORK ZONE, AS DIRECTED BY THE ENGINEER FOR THE DURATION OF THE PROJECT. THE SIGNS SHALL BE OF A TYPE SHOWN ON A LIST OF APPROVED CLASS "A" PCMS UNITS MAINTAINED BY THE ODOT DIRECTOR (OFFICE OF MATERIALS MANAGEMENT). THE APPROVED LIST OF PORTABLE CHANGEABLE MESSAGE SIGNS CAN BE FOUND ON THE ODOT WEBSITE BY CLICKING ON THE SERVICES MENU, THEN CLICKING ON MATERIALS MANAGEMENT.

EACH SIGN SHALL BE TRAILER-MOUNTED AND EQUIPPED WITH A FUNCTIONAL DIMMING MECHANISM, TO DIM THE SIGN DURING DARKNESS, AND A TAMPER AND VANDAL PROOF ENCLOSURE. EACH SIGN SHALL BE PROVIDED WITH APPROPRIATE TRAINING AND OPERATION INSTRUCTIONS TO ENABLE ON-SITE PERSONNEL TO OPERATE AND TROUBLESHOOT THE UNIT. THE SIGN SHALL ALSO BE CAPABLE OF BEING POWERED BY AN ELECTRICAL SERVICE DROP FROM A LOCAL UTILITY COMPANY. PCMS SHALL BE DELINEATED ON A PERMANENT BASIS IN ACCORDANCE WITH ODOT CMS 614.03.

THE PCMS LOCATIONS, LIMITS FOR THOSE LOCATIONS AND ALL ACTIVATION OF PCMS BY THE CONTRACTOR SHALL BE AS DIRECTED BY THE CHIEF ENGINEER. THE PCMS SHALL BE LOCATED IN A HIGHLY VISIBLE POSITION YET PROTECTED FROM TRAFFIC. THE CONTRACTOR SHALL, AT THE DIRECTION OF THE CHIEF ENGINEER, RELOCATE THE PCMS TO IMPROVE VISIBILITY OR ACCOMMODATE CHANGED CONDITIONS. WHEN NOT IN USE, THE PCMS SHALL BE TURNED OFF. ADDITIONALLY, WHEN NOT IN USE FOR EXTENDED PERIODS OF TIME, THE PCMS SHALL BE TURNED, FACING AWAY FROM ALL TRAFFIC, AND SHALL DISPLAY ONE OR MORE TYPE G YELLOW RETROREFLECTIVE SHEETING SURFACES OF 9-INCH BY 15-INCH MINIMUM SIZE FACING TRAFFIC.

THE CHIEF ENGINEER SHALL BE PROVIDED ACCESS TO EACH SIGN UNIT AND SHALL BE PROVIDED WITH APPROPRIATE TRAINING AND OPERATION INSTRUCTIONS TO ENABLE TURNPIKE MAINTENANCE PERSONNEL TO OPERATE AND TROUBLESHOOT THE UNIT, AND TO REVISE SIGN MESSAGES, IF NECESSARY.

ALL MESSAGES TO BE DISPLAYED ON THE SIGN WILL BE PROVIDED BY THE CHIEF ENGINEER. A LIST OF ALL REQUIRED PRE-PROGRAMMED MESSAGES WILL BE GIVEN TO THE CONTRACTOR AT THE PROJECT PRE-CONSTRUCTION CONFERENCE. THE SIGN SHALL HAVE THE CAPABILITY TO STORE UP TO 99 MESSAGES. MESSAGE MEMORY OR PRE-PROGRAMMED DISPLAYS SHALL NOT BE LOST AS A RESULT OF POWER FAILURES TO THE ON-BOARD COMPUTER. THE SIGN LEGEND SHALL BE CAPABLE OF BEING CHANGED IN THE FIELD. THREE-LINE PRESENTATION FORMATS WITH UP TO SIX MESSAGE PHASES SHALL BE SUPPORTED. PCMS FORMAT SHALL PERMIT THE COMPLETE MESSAGE FOR EACH PHASE TO BE READ AT LEAST TWICE.

THE PCMS SHALL CONTAIN AN ACCURATE CLOCK AND PROGRAMMING LOGIC WHICH WILL ALLOW THE SIGN TO BE ACTIVATED, DEACTIVATED OR MESSAGES CHANGED AUTOMATICALLY AT DIFFERENT TIMES OF THE DAY FOR DIFFERENT DAYS OF THE WEEK.

THE PCMS SHALL CONTAIN A CELLULAR TELEPHONE DATA LINK WHICH WILL (IN ACTIVE CELLULAR PHONE AREAS) ALLOW REMOTE ACTIVATION, MESSAGE CHANGES, MESSAGE ADDITIONS AND REVISIONS TO TIME OF DAY PROGRAMS. THE SYSTEM SHALL ALSO PERMIT VERIFICATION OF CURRENT AND PROGRAMMED MESSAGES. THE PCMS UNIT SHALL CONTAIN A GPS DEVICE WHICH WILL SHOW ITS LOCATION ON A MAP WHICH CAN BE VIEWED REMOTELY BY THE OTIC COMMUNICATIONS CENTER. ONE REMOTE DATA INPUT DEVICE (LAPTOP COMPUTER PLUS MODEM OR EQUIVALENT) SHALL BE FURNISHED FOR USE BY THE OTIC COMMUNICATIONS CENTER, OR EQUIVALENT, AND SHALL BE INSURED AGAINST THEFT.)

ALL PCMS UNITS SHALL BE EQUIPPED WITH RADAR THAT ENABLES THE MESSAGE BOARD TO DISPLAY THE SPEED OF THE APPROACHING VEHICLES. WHEN A PCMS IS INITIALLY BROUGHT OUT TO THE PROJECT THE CONTRACTOR SHALL CONTACT THE OTIC COMMUNICATIONS CENTER WITH THE PCMS NUMBER AND LOCATION. AT THAT TIME THE OTIC COMMUNICATIONS WILL VERIFY COMMUNICATION WITH THE PCMS.

WHEN A PCMS IS REPLACED OR RELOCATED THE CONTRACTOR SHALL CONTACT THE OTIC COMMUNICATIONS CENTER WITH THE PCMS NUMBER AND LOCATION.

THE PCMS UNIT SHALL BE MAINTAINED IN GOOD WORKING ORDER BY THE CONTRACTOR IN ACCORDANCE WITH THE PROVISIONS OF ODOT CMS 614.07. THE CONTRACTOR SHALL, PRIOR TO ACTIVATING THE UNIT, MAKE ARRANGEMENTS WITH AN AUTHORIZED SERVICE AGENT FOR THE PCMS, TO ASSURE PROMPT SERVICE IN THE EVENT OF FAILURE. ANY FAILURE SHALL NOT RESULT IN THE SIGN BEING OUT OF SERVICE FOR MORE THAN 12 HOURS, INCLUDING WEEKENDS. FAILURE TO COMPLY MAY RESULT IN AN ORDER TO STOP WORK AND OPEN ALL TRAFFIC LANES AND/OR IN THE CHIEF ENGINEER TAKING APPROPRIATE ACTION TO SAFELY CONTROL TRAFFIC. THE ENTIRE COST TO CONTROL TRAFFIC, ACCRUED BY THE OHIO TURNPIKE AND INFRASTRUCTURE COMMISSION DUE TO THE CONTRACTOR'S NONCOMPLIANCE, WILL BE DEDUCTED FROM MONEYS DUE, OR TO BECOME DUE THE CONTRACTOR ON THEIR CONTRACT.

THE CONTRACTOR SHALL BE RESPONSIBLE FOR 24-HOUR-PER-DAY OPERATION AND MAINTENANCE OF THESE SIGNS ON THE PROJECT FOR THE DURATION OF THE PHASES WHEN THE PLAN REQUIRES THEIR USE.

PAYMENT FOR THE ABOVE DESCRIBED ITEM SHALL BE AT THE CONTRACT UNIT PRICE. PAYMENT SHALL INCLUDE ALL LABOR, MATERIALS, EQUIPMENT, FUELS, LUBRICATING OILS, SOFTWARE, HARDWARE AND INCIDENTALS TO PERFORM THE ABOVE DESCRIBED WORK. THE CONTRACTOR SHALL ONLY BE PAID FOR PCMS UNITS WHEN THEY ARE IN OPERATION ON THE PROJECT AS SPECIFIED IN THE PLANS OR BY THE CHIEF ENGINEER.

THE FOLLOWING ESTIMATED QUANTITY HAS BEEN INCLUDED IN THE GENERAL SUMMARY FOR USE AS DIRECTED BY THE CHIEF ENGINEER TO PROVIDE THREE (3) PORTABLE CHANGEABLE MESSAGE SIGNS FOR APPROXIMATELY 180 DAYS IN SEASON ONE (1); AND TWO (2) PORTABLE CHANGEABLE MESSAGE SIGNS FOR APPROXIMATELY 157 DAYS IN SEASON TWO (2), FOR AN ESTIMATED TOTAL OF 28 SIGN MONTH.

ITEM 614, PORTABLE CHANGEABLE MESSAGE SIGN, AS PER PLAN  
28 SIGN MONTH

**ITEM SP 622 - PORTABLE BARRIER (WITH GLARE SCREEN)**  
**ITEM SP 622 - PORTABLE BARRIER (WITHOUT GLARE SCREEN)**  
THE CONTRACTOR SHALL REPLACE ANY DAMAGED PORTABLE BARRIER WITHIN 24 HOURS OF A DAMAGING IMPACT. TO FACILITATE THIS PROMPT REPLACEMENT, AN ADDITIONAL THREE HUNDRED FEET OF EACH TYPE OF BARRIER SHALL BE ON THE PROJECT AT ALL TIMES.

THE FOLLOWING CONTINGENCY QUANTITIES HAVE BEEN SHOWN FOR INFORMATIONAL PURPOSES ONLY. A LUMP SUM QUANTITY HAS BEEN CARRIED TO THE GENERAL SUMMARY FOR USE AS DIRECTED BY THE CHIEF ENGINEER FOR REPLACEMENT OF PORTABLE BARRIER.

ITEM SP 622 - PORTABLE BARRIER, 32"  
(WITH GLARE SCREEN) ..... 300 FEET

ITEM SP 622 - PORTABLE BARRIER, 32"  
(WITHOUT GLARE SCREEN) ..... 300 FEET

**SP 614, MAINTAINING TRAFFIC - ZONE PERSON**  
IN ADDITION TO THE REQUIREMENTS OF SP 614, WHEN TRAFFIC IS REDUCED TO ONE LANE EITHER EASTBOUND OR WESTBOUND ON THE TURNPIKE, THE CONTRACTOR'S ZONE PERSON AND ZONE VEHICLE SHALL CONCENTRATE THEIR EFFORTS ON THIS WORK ZONE.

DURING A TRAFFIC INCIDENT OR ANY OTHER OCCURRENCE CAUSING A TRAFFIC QUEUE, THE MAIN PRIORITY OF THE ZONE PERSON IS TO PROTECT THE BACK OF THE QUEUE. THIS SHALL BE ACCOMPLISHED BY POSITIONING THE ZONE VEHICLE ON THE ROADWAY SHOULDER AND APPROXIMATELY 1,000 FEET BEHIND THE REAR OF STOPPED/ SLOWED TRAFFIC, WHILE MOVING FORWARD OR BACKWARD AS NEEDED TO MAINTAIN THE PROPER DISTANCE. THE DISTANCE FROM THE QUEUE SHOULD BE INCREASED IF THERE IS LIMITED SIGHT DISTANCE DUE TO ROADWAY GEOMETRY.

PAYMENT FOR THE ABOVE SHALL BE INCLUDED IN THE CONTRACT PRICE FOR ITEM SP 614, MAINTAINING TRAFFIC. PAYMENT SHALL INCLUDE ALL LABOR, MATERIALS, AND EQUIPMENT NEEDED TO PERFORM THE ABOVE DESCRIBED WORK.

**PAVEMENT REPAIRS**

THE FOLLOWING QUANTITIES ARE INCLUDED AS A CONTINGENCY TO BE USED AS DIRECTED BY THE CHIEF ENGINEER FOR PAVEMENT REPAIR MEASURES TO MAINTAIN TRAFFIC. CONTRACTOR SHALL FOLLOW ODOT CMS FOR ITEM 255, EXCEPT THAT PLACEMENT OF THE DOWEL BARS ARE NOT REQUIRED FOR SHORT TERM REPAIRS (PAVEMENT AREAS WHICH WILL BE REPLACED WITH FULL DEPTH PAVEMENT AS PART OF THE ROADWAY WORK). CONCRETE SHALL BE CLASS QC 1 FOR AREAS WHERE TRAFFIC CAN BE DIVERTED FOR 7 DAYS, IN AREAS THAT HAVE TO BE OPENED TO TRAFFIC IN A TIMELY MANNER CONCRETE SHALL BE IN ACCORDANCE WITH ODOT 255.02A.

FOR ITEM 251, PARTIAL REMOVAL AND REPLACEMENT DEPTH WILL BE 5" (+/-) ASPHALT CONCRETE TO THE SURFACE OF THE EXISTING CEMENT CONCRETE BASE. REPLACEMENT MATERIALS ARE SPECIFIED IN 251.03.

MAINTENANCE OF TRAFFIC COSTS INCURRED BY THE CONTRACTOR FOR THESE CURRENTLY UNKNOWN AND UNDEFINED PAVEMENT REPAIRS WILL BE COMPENSATED ON A TIME AND MATERIALS BASIS AS APPROVED BY THE CHIEF ENGINEER.

ITEM 251 - PARTIAL DEPTH PAVEMENT REPAIR.....500 SQ. YD.  
ITEM 255 - FULL DEPTH PAVEMENT REMOVAL AND RIGID REPLACEMENT.....500 SQ. YD.  
ITEM 255 - FULL DEPTH PAVEMENT REMOVAL AND RIGID REPLACEMENT  
(USING RAPID REPAIR CONCRETE MIX MATERIAL).....500 SQ. YD.  
ITEM 255 - FULL DEPTH PAVEMENT SAWING.....1500 FT.

**CONTRACTOR STAGING AREA**

TOLL PLAZA 187 INFIELD IS AVAILABLE FOR A CONTRACTOR STAGING AREA. IF A CONTRACTOR CHOOSES A STAGING AREA WITHIN THE TURNPIKE RIGHT OF WAY OTHER THAN WHAT IS INDICATED IN THE PLANS, IT MUST BE SUBMITTED TO THE CHIEF ENGINEER FOR APPROVAL PRIOR TO USE.

THE STAGING AREA SHALL BE MAINTAINED BY THE CONTRACTOR AND RESTORED TO ORIGINAL CONDITION TO THE APPROVAL OF THE CHIEF ENGINEER PRIOR TO COMPLETION OF ALL WORK.

	DESIGN AGENCY	BY DATE	REVISIONS	NO.	CHECKED	DESIGNED	MAINTENANCE OF TRAFFIC GENERAL NOTES PORTAGE COUNTY M.P. 186.0 AND M.P. 186.8	PROJECT 43-18-04 DATE: 10/25/17	OHIO TURNPIKE
	PALMER ENGINEERING 460 WYVIE POINTE DRIVE, SUITE 200 AKRON, OH 44320 PHONE: 330.933.1111 FAX: 330.933.1100	DAM 01/18	ADDENDUM 1	1	MAM	DAM			
		DAM 01/18	ADDENDUM 2	2	IN CHARGE				
					MAM				

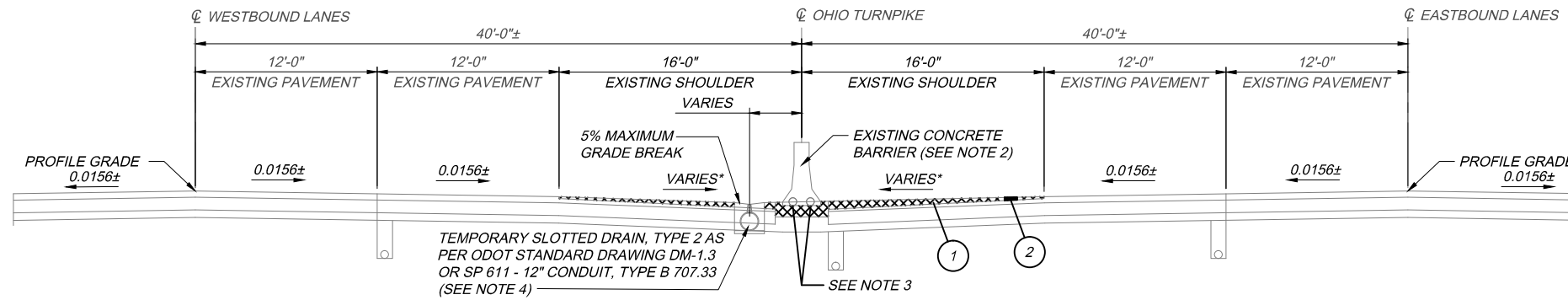

**MEDIAN TEMPORARY PAVEMENT AND DRAINAGE SECTION - PHASE 1**

STATION 6+35 TO STATION 12+95  
STATION 20+20 TO STATION 26+80  
(SEE NOTE 2 FOR EXISTING MEDIAN BARRIER REMOVAL LIMITS)

\* = 0.02 MAX

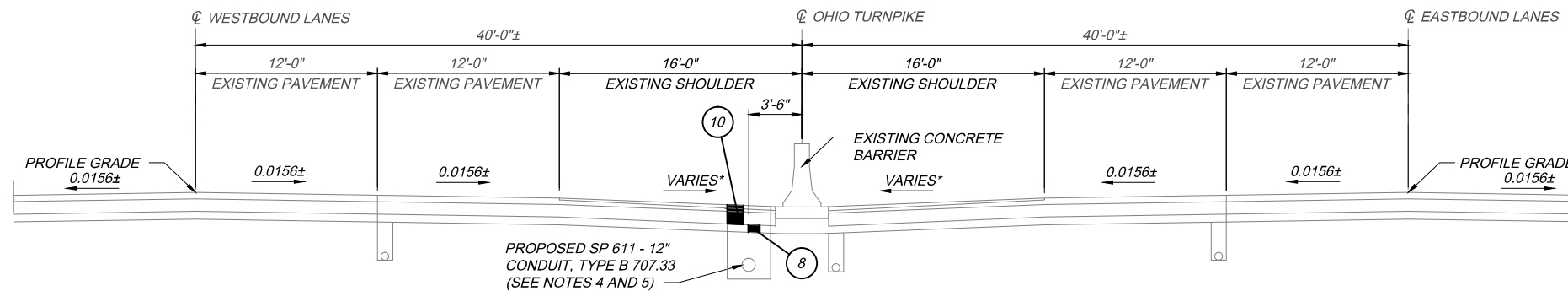

**MEDIAN CONDUIT SECTION - PHASE 1**

STATION 1+96 TO STATION 6+85

**LEGEND**

- = TEMPORARY PAVEMENT MINIMUM 1 1/2" THICKNESS
- ① ITEM SP 404 - ASPHALT CONCRETE SURFACE COURSE, USING CRUSHED STONE, PG64-22. (1 1/2" MINIMUM)
- ② ITEM 254 - PAVEMENT PLANING, ASPHALT CONCRETE (VARIABLE DEPTH)
- ③ NOT USED
- ④ ITEM 622 - CONCRETE BARRIER TYPE B-50, AS PER PLAN
- ⑤ SP 404A - JOINT SEALER (APPLIED TO VERTICAL FACE)
- ⑥ SPECIAL - SAWCUT JOINT
- ⑦ ITEM 407 - NON-TRACKING TACK COAT
- ⑧ SP 304 - AGGREGATE BASE (6")
- ⑨ SP 304 - GRANULAR EMBANKMENT (VARIABLE DEPTH)
- ⑩ ITEM 302 - BITUMINOUS AGGREGATE BASE, PG64-22 (15")
- ⑪ ITEM SPECIAL - SONIC NAP ALERT PATTERN

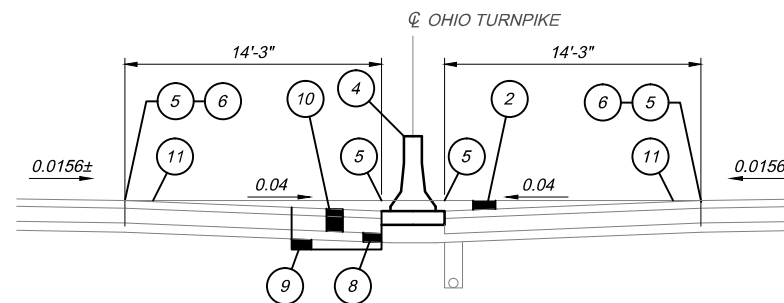

**MEDIAN RESTORATION TYPICAL SECTION - PHASE 4**

STATION 6+35 TO STATION 12+95  
STATION 20+20 TO STATION 26+80  
(SEE NOTE 4 FOR FULL DEPTH PAVEMENT REQUIREMENTS)  
(SEE NOTE 6 FOR PHASE 4 MEDIAN BARRIER REPLACEMENT LIMITS)

**NOTES:**

1. THE CONTRACTOR SHALL REMOVE THE EXISTING SURFACE COURSE OF ASPHALT WITHIN THE LIMITS OF THE TEMPORARY PAVEMENT IN ORDER TO PROVIDE THE MINIMUM 1 1/2" PAVEMENT THICKNESS. COST OF REMOVAL, TACK COAT AND PLACEMENT OF VARIABLE DEPTH TEMPORARY PAVEMENT TO BE INCLUDED IN THE LUMP SUM BID FOR ITEM SP 614, MAINTAINING TRAFFIC.
2. CONTRACTOR SHALL REMOVE ENTIRE EXISTING PERMANENT MEDIAN BARRIER DURING PHASE 1 DEMOLITION OPERATIONS STATION 6+85 TO STATION 12+45, STATION 20+70 TO 21+40 AND STATION 24+50 TO STATION 26+30. REMOVE EXISTING TEMPORARY MEDIAN BARRIER FROM PROJECT 39-16-02 STATION 21+40 TO STATION 24+50. MEDIAN BARRIER FOUNDATION MAY REMAIN DURING CONSTRUCTION AND BE REPLACED DURING THE PHASE 4 CROSSOVER RESTORATION.
3. THE CONTRACTOR SHALL TERMINATE THE MULTICELL CONDUIT BY PERMANENT CAPPING. THE CONTRACTOR SHALL NOT REPLACE THE MULTICELL CONDUIT. LABOR, EQUIPMENT, AND MATERIALS FOR THE ABOVE DESCRIBED WORK SHALL BE INCLUDED IN THE LUMP SUM BID FOR ITEM SP 614, MAINTAINING TRAFFIC.
4. SEE SHEETS 18 - 20 FOR PHASE 1 CONDUIT LIMITS. PLACE FULL DEPTH PAVEMENT IN AREAS WHERE TEMPORARY DRAINAGE FEATURES ARE REMOVED DURING PHASE 4.
5. 12" TYPE B CONDUIT PLACED IN PHASE 1 PER SP 611 TO REMAIN.
6. CONTRACTOR SHALL CONSTRUCT ITEM 622 - CONCRETE BARRIER TYPE B-50, AS PER PLAN FROM STATION 6+85 TO STATION 12+45 AND FROM STATION 20+70 TO STATION 26+30 DURING PHASE 4.
7. ALL COSTS ASSOCIATED WITH THE MEDIAN RESTORATION INCLUDING, BUT NOT LIMITED TO, THE REMOVAL OF THE TEMPORARY PAVEMENT. REMOVAL OF ALL THE TEMPORARY DRAINAGE ITEMS, MEDIAN BARRIER REPLACEMENT, PAVEMENT REPLACEMENT, FILLING AND PLUGGING CONDUIT, AND PERMANENT DRAINAGE ITEMS, UNLESS ITEMIZED SEPARATELY, SHALL BE INCLUDED IN THE LUMP SUM BID FOR ITEM SP 614, MAINTAINING TRAFFIC.

711609\_MY003.dwg: 1/20/18 - 6:19pm

 <b>Palmer Engineering</b> 460 WYVIE POND DRIVE, SUITE 300 AKRON, OH 44320 (330) 475-1100 WWW.PALMERENGINEERING.COM	DESIGN AGENCY
	BY DATE
	DAM 01/18
	ADDENDUM 2
NO.	2
CHECKED	MAM
DESIGNED	MAM
DRAWN	WB
<b>MAINTENANCE OF TRAFFIC TYPICAL SECTIONS</b> <b>OHIO TURNPIKE OVER WHEELING AND LAKE ERIE RAILWAY</b> PORTAGE COUNTY M.P. 186.0	<b>PROJECT 43-18-04</b> DATE: 10/25/17

711609\_I480\_MP002.dwg: 1/12/18 - 12:25pm

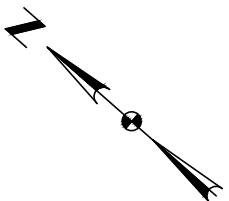
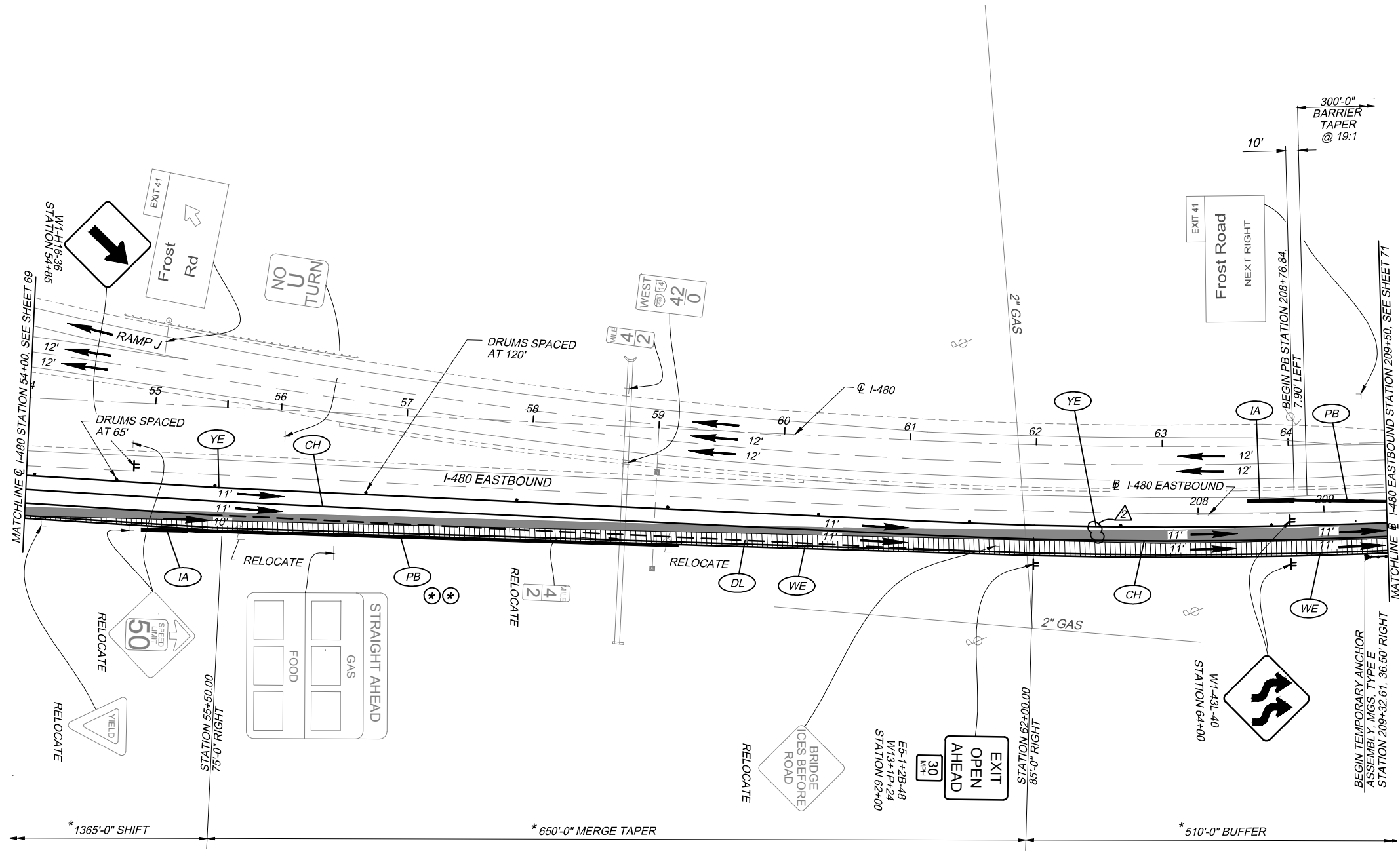

⊛ ⊛ PLACE PORTABLE BARRIER IN ACCORDANCE WITH ODOT REQUIREMENTS TO PROTECT TEMPORARY LIGHT POLE RELOCATION.

\* MEASURED ALONG C I-480

NOTES:  
1. SEE SHEET 67 FOR LEGEND.

	<b>PROJECT 43-18-04</b> MAINTENANCE OF TRAFFIC PLAN - PHASE 3 INTERSTATE ROUTE I-480 EASTBOUND OVER OHIO TURNPIKE PORTAGE COUNTY M.P. 186.8	DESIGNED <b>DAM</b> DRAWN <b>TGW</b>	CHECKED <b>MAM</b> IN CHARGE <b>MAM</b>	NO. <b>2</b>	REVISIONS ADDENDUM 2	BY <b>DAM</b>	DATE <b>01/18</b>	DESIGN AGENCY  PALMER ENGINEERING 460 WYVIE POND DRIVE, SUITE 200 AKRON, OH 44320 330.444.4444	
		<b>OHIO TURNPIKE AND INFRASTRUCTURE COMMISSION</b>							

70  
113

OT\_MP186.8\_SM001.dwg: 1/21/18 - 1:33pm

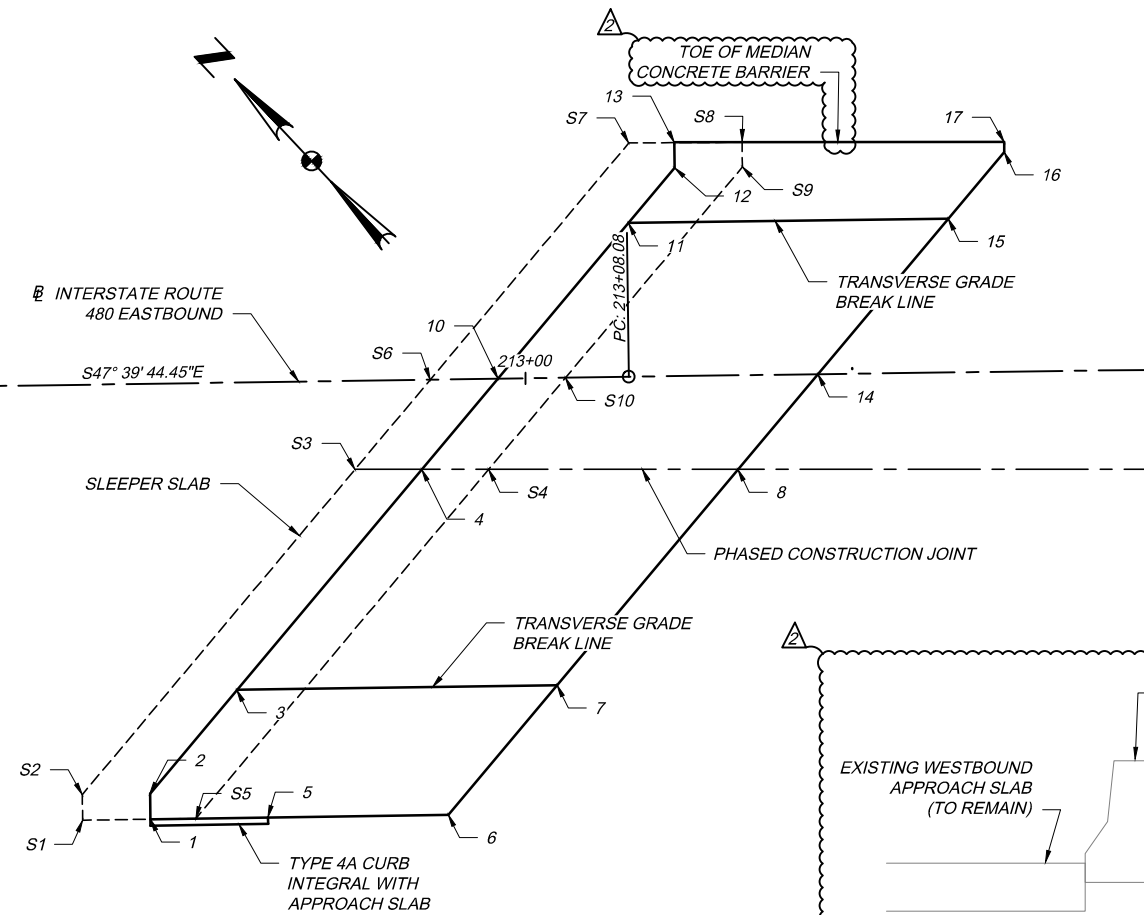

REAR APPROACH SLAB PLAN

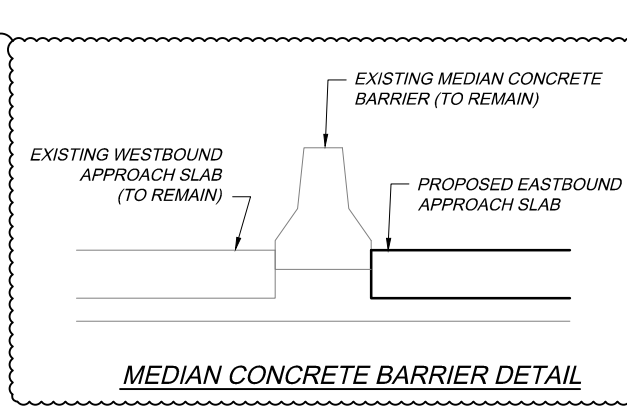

MEDIAN CONCRETE BARRIER DETAIL

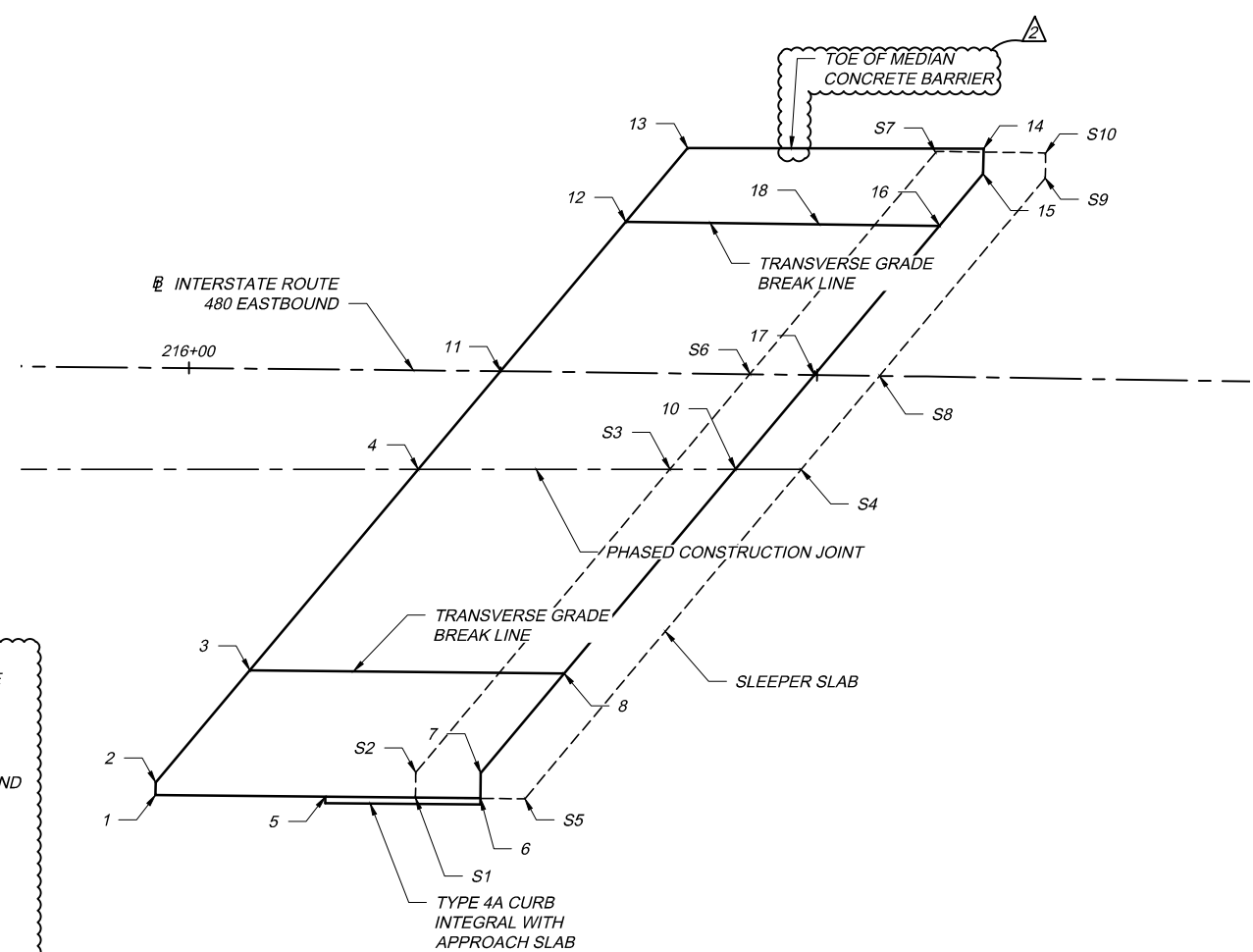

FORWARD APPROACH SLAB PLAN

REAR APPROACH SLAB SURFACE ELEVATIONS					REAR SLEEPER SLAB SURFACE ELEVATIONS				
PHASE	POINT	STATION	OFFSET	ELEVATION	PHASE	POINT	STATION	OFFSET	ELEVATION
PHASE 1	1	212+70.19	34' RT	1057.83	PHASE 1	S1	212+64.90	34' RT	1056.41
	2	212+70.19	32' RT	1057.91		S2	212+64.90	32' RT	1056.49
	3	212+77.11	24' RT	1058.44		S3	212+86.58	6.92' RT	1057.76
	4	212+91.80	7' RT	1059.17		S4	212+97.02	7.08' RT	1058.08
	5	212+79.38	34' RT	1058.21		S5	212+73.75	34' RT	1056.73
	6	212+93.47	34' RT	1058.80		S6	212+92.56	0'	1058.05
	7	213+02.11	24' RT	1059.23		S7	213+08.34	18.25' LT	1058.11
	8	213+16.50	7.36' RT	1059.94		S8	213+17.17	18.17' LT	1058.43
PHASE 2	9	NOT USED			PHASE 2	S9	213+17.16	16.25' LT	1058.49
	10	212+97.85	0'	1059.47		S10	213+03.14	0'	1058.39
	11	213+08.22	12' LT	1059.61					
	12	213+11.89	16.25' LT	1059.55					
	13	213+11.89	18.25' LT	1059.47					
	14	213+22.85	0'	1060.25					
	15	213+33.18	12' LT	1060.39					
	16	213+37.61	17.15' LT	1060.45					
	17	213+37.62	17.92' LT	1060.44					

FORWARD APPROACH SLAB SURFACE ELEVATIONS					FORWARD SLEEPER SLAB SURFACE ELEVATIONS					
PHASE	POINT	STATION	OFFSET	ELEVATION	PHASE	POINT	STATION	OFFSET	ELEVATION	
PHASE 1	1	215+97.64	34' RT	1066.31	PHASE 1	S1	216+18.38	34' RT	1065.21	
	2	215+97.64	33' RT	1066.33		S2	216+18.38	32' RT	1065.28	
	3	216+05.06	24' RT	1066.59		S3	216+38.37	7.65' RT	1066.08	
	4	216+18.33	7.88' RT	1067.04		S4	216+48.82	7.52' RT	1066.23	
	5	216+11.18	34' RT	1066.40		S5	216+27.11	34' RT	1065.27	
	6	216+23.57	34' RT	1066.47		S6	216+44.46	0'	1066.29	
	7	216+23.57	32' RT	1066.55		S7	216+59.18	17.84' LT	1066.09	
	8	216+30.15	24' RT	1066.96		S8	216+54.97	0'	1066.42	
	9	NOT USED					S9	216+67.93	15.92' LT	1066.28
	10	216+43.60	7.59' RT	1067.41		S10	216+67.93	17.92' LT	1066.20	
PHASE 2	11	216+24.80	0'	1067.26						
	12	216+34.62	12' LT	1067.21						
	13	216+39.46	17.92' LT	1067.19						
	14	216+62.99	18.18' LT	1067.37						
	15	216+62.99	16.18' LT	1067.45						
	16	216+59.58	12' LT	1067.56						
	17	216+49.80	0'	1067.61						
	18	216+50.00	12' LT	1067.42						

NOTES

- SEE ODOT STANDARD DRAWINGS AS-1-15 AND AS-2-15 FOR ADDITIONAL DETAILS AND NOTES.
- THE JOINT BETWEEN THE APPROACH SLAB AND THE ROADWAY PAVEMENT SHALL BE SEALED PER ODOT STANDARD DRAWING AS-1-15, DETAIL C ON SHEET 2 OF 2.
- PROVIDE MECHANICAL CONNECTORS PER CMS 509.07 AT THE PHASE CONSTRUCTION JOINT FOR THE TOP AND BOTTOM B BARS. THE COST OF THE MECHANICAL CONNECTORS SHALL BE INCIDENTAL TO ITEM 526.
- LONGITUDINAL AND TRANSVERSE CONSTRUCTION JOINTS SHALL BE TREATED IN ACCORDANCE WITH ITEM SP 516B - SEALING OF CONSTRUCTION JOINTS.

PROJECT 43-18-04

DATE: 10/23/17

1 / 1

103  
113

APPROACH SLAB DETAILS  
INTERSTATE ROUTE 480 EASTBOUND OVER OHIO TURNPIKE  
M.P. 186.8  
PORTAGE COUNTY

DESIGNED BY: TES  
DRAWN BY: TES  
CHECKED BY: JPR  
IN CHARGE: MLJ  
NO. 2  
REVISIONS: ADDENDUM 2  
BY DATE: JPR 01/18

DESIGN AGENCY: PALMER ENGINEERING  
480 WHITE POND DRIVE, SUITE 300  
AKRON, OH 44320  
OHIO TURNPIKE

OHIO TURNPIKE AND INFRASTRUCTURE COMMISSION

OHIO TURNPIKE

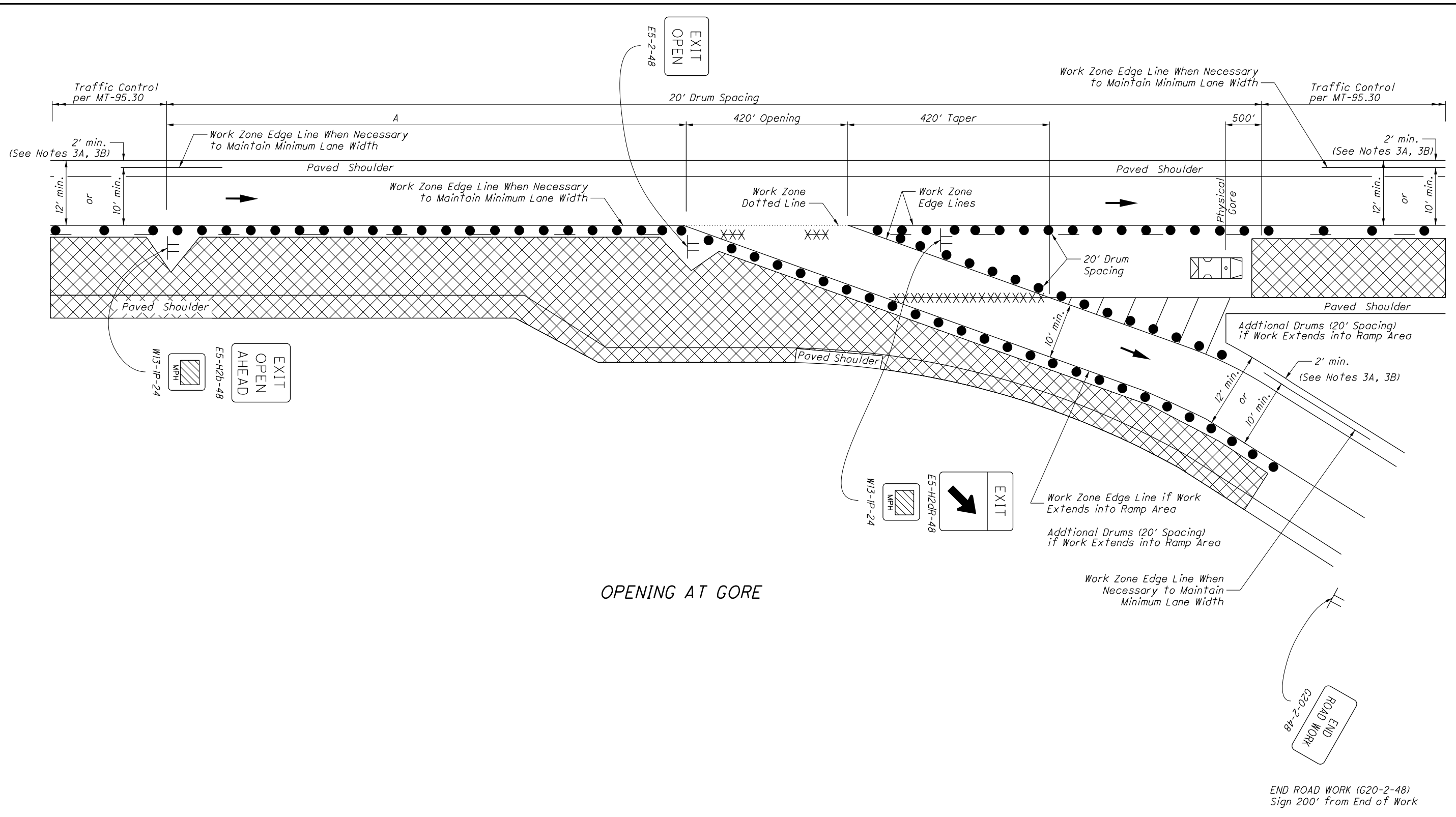

OPENING AT GORE

**LEGEND**

WORK AREA	
DRUMS/CONES	
REMOVE EXISTING MARKINGS	
DIRECTION OF TRAVEL	
SHADOW VEHICLE	

**TABLE I (SIGN SPACING)**

ROAD TYPE	DISTANCE (A) BETWEEN SIGNS (FT)
MAJOR CONVENTIONAL	500
FREEWAY & EXPRESSWAY	1000

**TABLE III (RAMP DESIGN SPEED)**

MAINLINE DESIGN SPEED (MPH)	30	35	40	45	50	55	60	65	70	75
RAMP DESIGN SPEED (MPH)	25	30	35	40	45	48	50	55	60	65



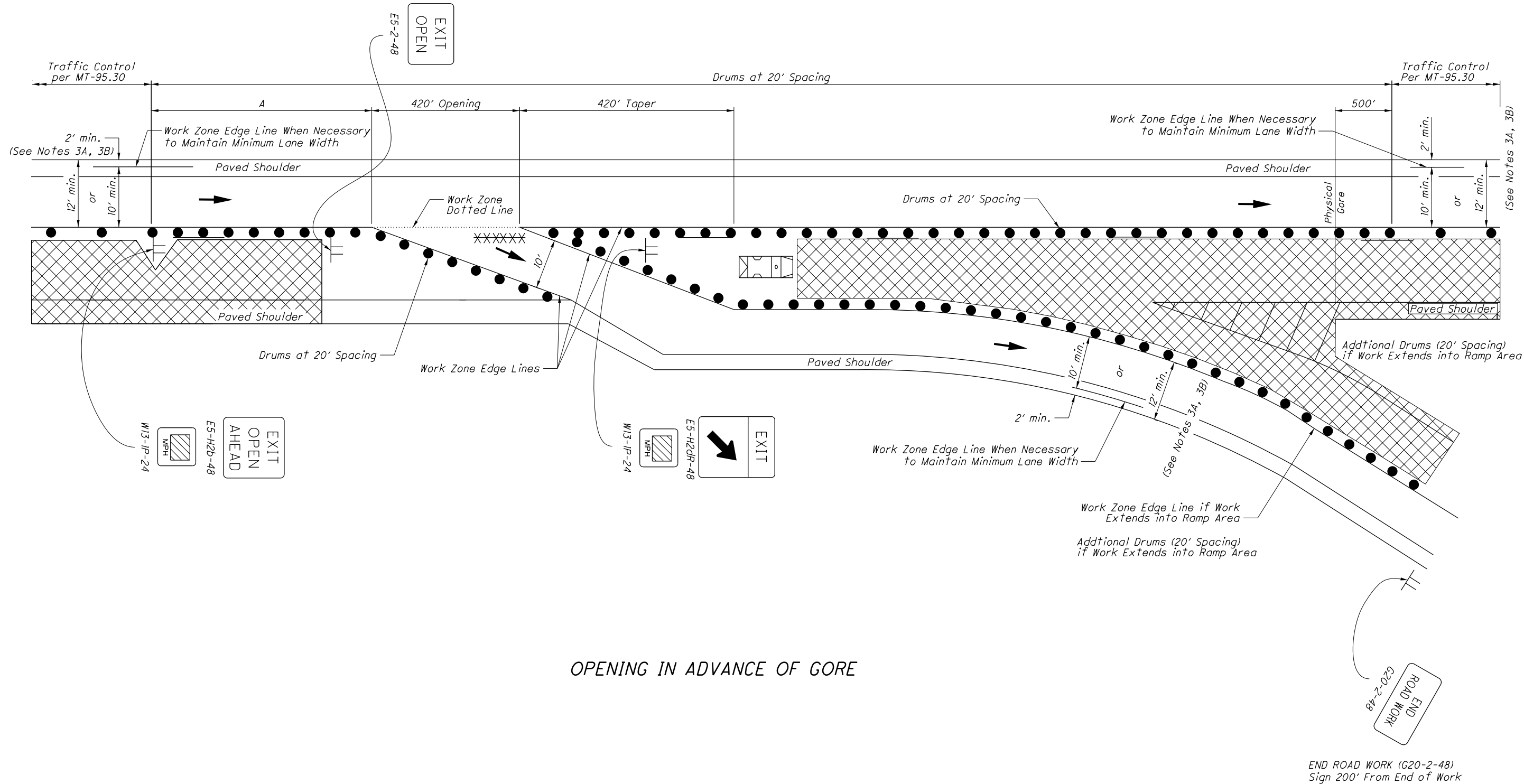

OPENING IN ADVANCE OF GORE

**LEGEND**

WORK AREA	
DRUMS/CONES	
REMOVE EXISTING MARKINGS	
DIRECTION OF TRAVEL	
SHADOW VEHICLE	

**TABLE I (SIGN SPACING)**

ROAD TYPE	DISTANCE (A) BETWEEN SIGNS (FT)
MAJOR CONVENTIONAL	500
FREEWAY & EXPRESSWAY	1000

**TABLE III (RAMP DESIGN SPEED)**

MAINLINE DESIGN SPEED (MPH)	30	35	40	45	50	55	60	65	70	75
RAMP DESIGN SPEED (MPH)	25	30	35	40	45	48	50	55	60	65

NOTES:

SIGNING

- IA. All signs approaching the exit shall be dual-mounted where two or more lanes remain open.
- IB. The Advisory Speed (W13-IP) plaque shall be used when specified in the plan, or when it is necessary for the vehicle to reduce speed by more than 10 mph in order to safely exit from the mainline, as directed by the Engineer. The following additional criteria shall also apply:
  - a) Advisory speeds within 10 mph of the posted speed limit need not be displayed.
  - b) When provided at exit ramp openings (see Note 2A), the Advisory Speed plaque should typically be mounted below the EXIT (arrow) (E5-H2d) sign. The Advisory Speed plaque shall not be mounted below the Permanent Gore (E5-H1a) sign. As an alternative, the Advisory Speed plaque may be mounted below the EXIT OPEN (E5-2) sign.
  - c) The advisory speed displayed shall not be greater than would otherwise be required to accommodate the permanent ramp geometry at the exit.
- IC. END ROAD WORK (G20-2) signs are only required for lane closures of more than 1 day. It is intended that these signs be placed on the mainline, on all exit ramps, and on roadways exiting the work limits. Any END ROAD WORK sign which would fall within the limits of another work zone may be omitted.
- ID. The work zone sign spacings shown in Table I are minimums. Maximum spacings should not be greater than 1.5 times the distances shown in Table I.
- IE. Sign spacing should be adjusted to avoid conflict with existing signs. Minimum spacing to existing signs shall be 200' for speeds of 45 mph or less and a minimum of 400' for speeds of 50 mph or greater.
- IF. For advance signing and pavement marking, and any other traffic control procedure to be implemented approaching the subject location, see Standard Construction Drawings (SCDs) MT-95.30, MT-95.40 or the MT-102 series as may be appropriate.

RAMP OPENING

- 2A. The opening to the ramp should be 420' or more whenever possible. A lesser opening may be provided if no other alternative is available. When a lesser opening is provided, the advisory speed applicable to such condition shall be as follows:

<u>Opening/Taper</u>	<u>Advisory Speed</u>
390'	65 mph
360'	60 mph
330'	55 mph
300'	50 mph
270'	45 mph
240'	40 mph
210'	35 mph

- 2B. The opening shall never be less than 200'. If a 200' minimum dimension cannot be provided, the ramp should be closed when so determined by the Engineer.

RAMP WIDTH

- 3A. Normally a 10' minimum ramp width is to be maintained on existing ramp pavement.

- 3B. Where the condition in Note 3A is not possible, a minimum width of 12' to the outside edge of the paved shoulder may be used only if the shoulder pavement buildup is adequate to carry the load. Where an edge line is required to designate a shoulder, the edge line shall be placed such that the minimum lane width is 10' and the minimum shoulder width is 2'.

PAVEMENT MARKING

- 4A. If the construction operation requires a lane closure for more than 1 day, the existing conflicting reflectors from the raised pavement markers shall be removed.
- 4B. Additionally, if a lane closure of greater than 3 days is required, the appropriate color work zone edge lines shall be applied along the taper, and existing conflicting pavement markings shall be removed or covered as per CMS 614.11G.
- 4C. Work zone pavement markings which would conflict with the final traffic lanes shall be removable tape (CMS 740.06, Type I) unless the area will be resurfaced prior to project completion.
- 4D. After completion of the work, pavement markings other than CMS 740.06, Type I shall be removed in accordance with CMS 614.11I. The original markings and raised pavement marker reflectors shall be restored at no additional cost unless separately itemized in the plans.

(RESERVED FOR FUTURE USE)

- 5A. (intentionally blank)

DRUMS / CONES

- 6A. Drum spacing shall be as follows:
  - a) 20' center-to-center within the vicinity of the exit gore, and continuing to a point 500' beyond the end of the physical gore.
  - b) As shown on SCD MT-95.30 elsewhere along the mainline; and
  - c) 20' center-to-center along the ramp.
- 6B. Cones may be substituted for drums as follows:
  - a) Use of cones is permissible for either daytime operation or for nighttime operation, but shall not be used continuously, day and night. Upon completion of work within the work period, the cones shall be removed. They may again be placed on the highway in order to resume work in the following such work period.
  - b) Cones used for daytime traffic control shall have a minimum height of 28".
  - c) Cones used for nighttime traffic control shall have a minimum height of 42".
  - d) Use of cones at night shall be prohibited along tapers.
  - e) Cone spacing at night shall be at a maximum of 40' but shall never be greater than the drum spacing called for in Note 6A.
  - f) Where cones are substituted for drums along tangents, intermixing of channelizing devices within the same run will not be permitted. Either cones shall be used for the entire length of the tangent section, or drums shall be used for the entire run.
- 6C. Provisions shall be made to stabilize cones and drums per the manufacturer's specifications to prevent them from blowing over.

SHADOW VEHICLE

- 7A. The shadow vehicle shall be in place and unoccupied whenever workers are in the work area. This vehicle shall be removed from the pavement whenever workers are not in the work area.
- 7B. The shadow vehicle shall be equipped with a high-intensity yellow rotating, flashing, oscillating, or strobe light(s), clearly visible a minimum of one-quarter mile.
- 7C. The vehicle shall be equipped with a truck-mounted attenuator when specified in the plans.
- 7D. Other protective devices may be used in lieu of the shadow vehicle shown when approved by the Engineer.

THIS DRAWING REPLACES MT-98.20 DATED 07-19-2013.

STANDARD ROADWAY CONSTRUCTION DRAWING

LANE CLOSURE AT EXIT RAMP USING DRUMS

SCD NUMBER  
**MT - 98.20**

OFFICE OF  
ROADWAY  
ENGINEERING

STATE ENGINEER  
Soisson

STATE OF OHIO DEPARTMENT OF  
TRANSPORTATION ADMINISTRATOR  
Reynaldo Stargell

REVISION DATE  
07-18-2014