

- NOTES:
1. WALLS: THE WALLS BETWEEN THE BOTTOM SLAB AND THE UPPER PERMISSIBLE CONSTRUCTION JOINT MAY BE BUILT OF CAST-IN-PLACE CONCRETE OR PRECAST. CAST-IN-PLACE CONCRETE SHALL HAVE A WALL THICKNESS OF 8" NOMINAL FOR DEPTHS OF 12' OR LESS. PRECAST WALLS SHALL HAVE A MINIMUM THICKNESS OF 6" AND BE REINFORCED SUFFICIENTLY TO PERMIT SHIPPING AND HANDLING WITHOUT DAMAGE. THE UNIT ABOVE THE UPPER PERMISSIBLE CONSTRUCTION JOINT MAY BE PRECAST OR CAST-IN-PLACE.
 2. CONCRETE: CAST-IN-PLACE, TO BE CLASS QC1 CONCRETE. ALL PRECAST CONCRETE SHALL MEET THE REQUIREMENTS OF CMS 706.13 WITH 6 ±2% AIR VOID CONTENT IN THE HARDENED CONCRETE. REQUIRED MARKINGS SHALL INCLUDE STATION, LOCATION, AND OFFSET WITH INLET NUMBER. PRECAST UNITS SHALL BE BACKFILLED WITH LOW STRENGTH MORTAR, TYPE 2 AS PER SP 611 AND ITEM 613.
 3. STEPS AND CASTING: STEPS SHALL BE IN ACCORDANCE WITH ODOT STANDARD DRAWING MH-1.1. CASTING: MINIMUM WEIGHT OF FRAME AND COVER SHALL BE 540 POUNDS.
 4. OPENINGS: PIPE OPENINGS SHALL BE OUTSIDE DIAMETER PLUS 2" WHEN PREFABRICATED OR CORED. FILL ANY VOIDS PER SP 611.
 5. INLETS OVER 12 FEET IN DEPTH: SUCH INLETS SHALL BE PRECAST OF CAST-IN-PLACE CONCRETE, REINFORCED WITH EPOXY COATED #5 BARS ON 12" CENTERS BOTH VERTICALLY AND HORIZONTALLY WITH 2" CLEARANCE FROM THE INSIDE WALL FACE.
 6. THE FOLLOWING TEXT SHALL BE CAST INTO THE TOP OF THE GRATE: **"DUMP NO WASTE"** AND **"DRAIN TO WATERWAY"** TEXT SHALL BE PRINTED IN BOLD, CAPITAL LETTERS WITH A MINIMUM HEIGHT OF 1/2". **"WATERWAY"** MAY BE SUBSTITUTED WITH **"STREAM"**, **"RIVER"**, **"LAKE"**, ETC. ACTUAL PLACEMENT AND LOGO MAY VARY PER MANUFACTURER.
 7. CONCRETE BARRIER: FOR DETAILS AND NOTES FOR SINGLE SLOPE CONCRETE BARRIER, TYPE B-50, AS PER PLAN, SEE STANDARD DRAWING CBR-2 SHEET 1 OF 3. REINFORCING SHALL BE EPOXY COATED IN ACCORDANCE WITH CMS 509.09.
 8. PAYMENT: PAYMENT WILL BE MADE AT THE UNIT PRICE BID PER EACH FOR SP 611 - INLET, NO. I-3B50, DOUBLE GRATE AND SHALL INCLUDE ALL MATERIALS, REINFORCING STEEL AND CASTINGS AND LABOR REQUIRED TO CONSTRUCT THE INLET AS SHOWN, COMPLETE AND ACCEPTED.
 9. THE USE OF BRICK OR MASONRY BLOCK TO BUILD THE CATCH BASIN SHALL BE PROHIBITED. IF THE FRAME DOES NOT SIT ON THE CATCH BASIN WALLS, THE CONTRACTOR SHALL FORM AND POUR, USING CLASS "QC MS" CONCRETE, TO BUILD THE CATCH BASIN TO SECURE CONCRETE TO THE EXISTING PRECAST STRUCTURE. THE CONTRACTOR SHALL INSTALL #4 DOWEL BARS, SPACED 12" O/C (3 PER SIDE UNLESS DIRECTED OTHERWISE BY THE CHIEF ENGINEER) IN ACCORDANCE WITH ITEMS 509 AND 510. THE DOWEL BARS SHALL BE IMBEDDED AT LEAST 6" INTO THE EXISTING PRECAST STRUCTURE AND SECURED WITH NON-SHRINK NON-METALLIC GROUT THAT CONFORMS TO CMS 705.20. THE CONTRACTOR SHALL USE FORMS SIZED TO CONFORM TO THE INTERIOR OF THE CATCH BASIN, AND THAT WILL INSURE A SMOOTH INTERIOR FINISH. ALL OTHER CONCRETE SURFACES SHALL HAVE A BROOMED FINISH. AFTER THE CASTING IS SET TO THE FINAL GRADE, THE AREA AROUND THE ADJUSTED CATCH BASIN CASTING SHALL BE BACK FILLED WITH CLASS "QC MS" CONCRETE TO THE EXISTING SURFACE.

CB-4A 2018.09.19.dwg; 9/26/18 - 2:26pm

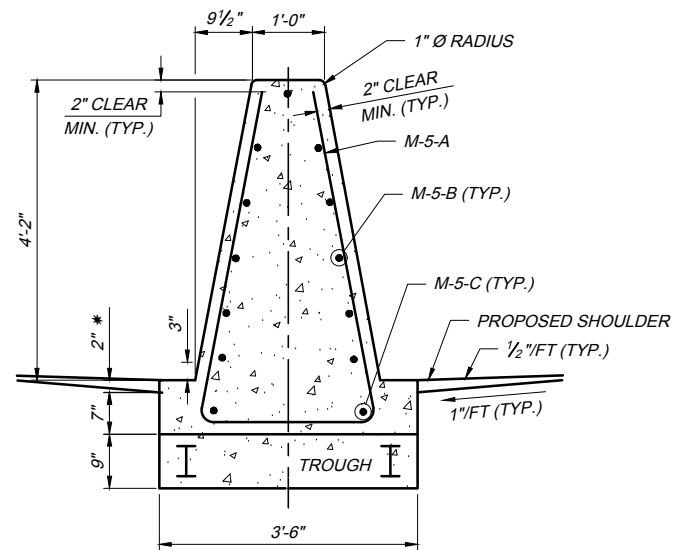

SECTION B-B

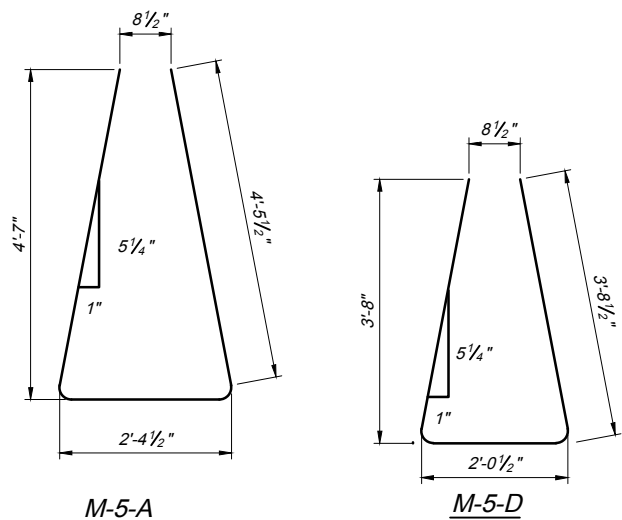

BAR BENDING DIAGRAM

STEEL LIST									
M-5-A		M-5-B		M-5-C		M-5-D		S6 X 12.5	
NO.	LENGTH	NO.	LENGTH	NO.	LENGTH	NO.	LENGTH	NO.	LENGTH
8	11'-5"	11	19'-8"	4	4'-8"	5	9'-5"	2	11'-0"

NOTE:

* THE DIFFERENCE BETWEEN THE NORMAL GRADE ELEVATION AND THE \bar{E} INLET GRATE ELEVATION IS 2".

** NORMAL GRADE ELEVATION

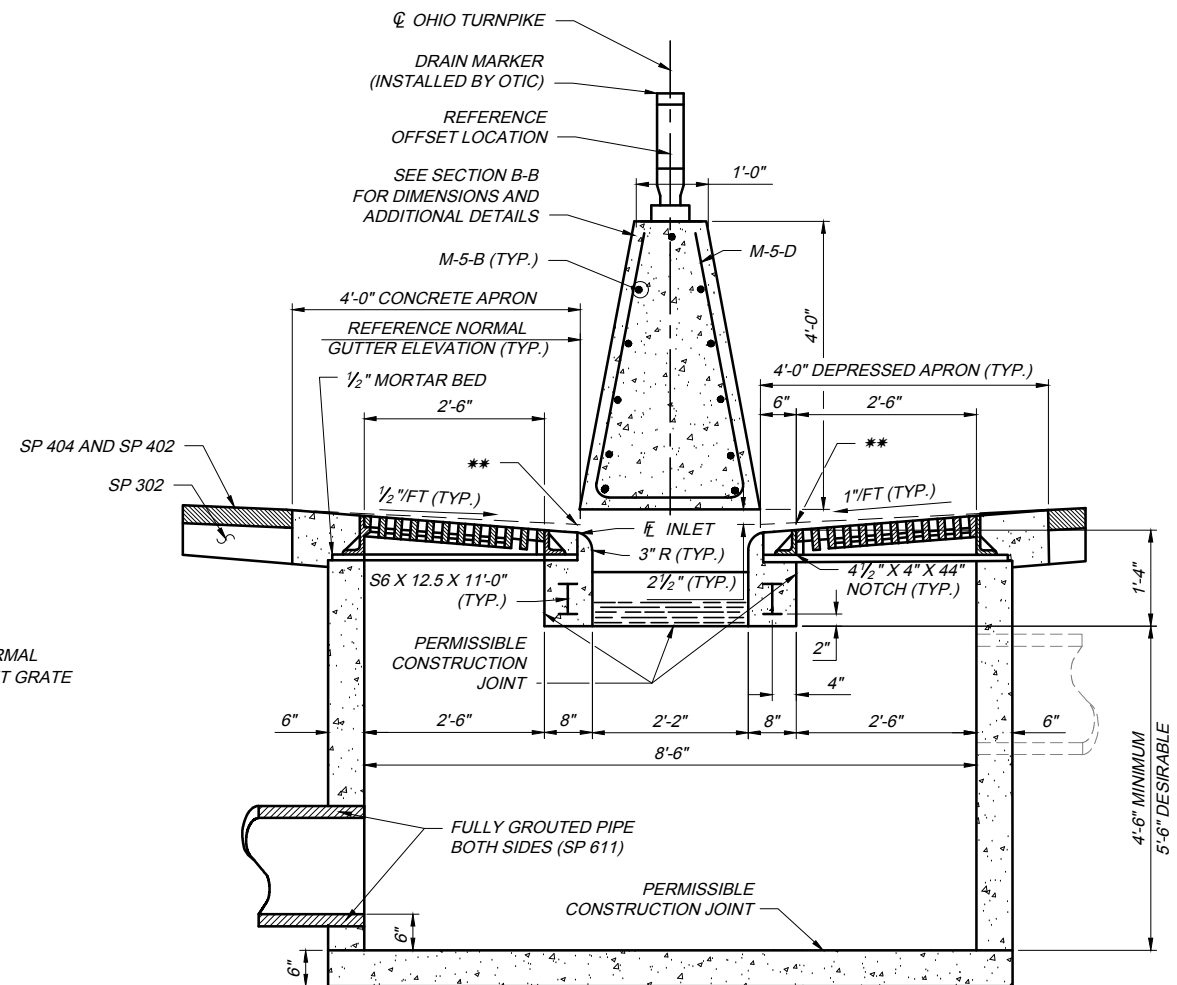

SECTION C-C

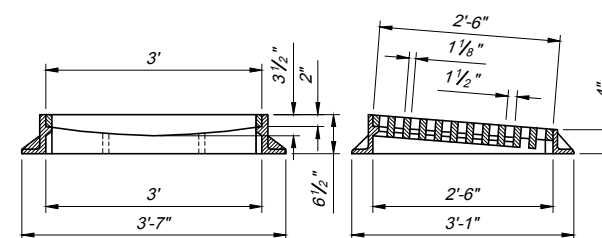

CASTING DETAILS

NOTE:

FOR STANDARD INLET TYPES, NOTES, LEGENDS, PLAN AND SECTION A-A, SEE SHEET 1 OF 2.