

CL-2-2023.10.17.dwg; 10/18/23 - 1:32pm

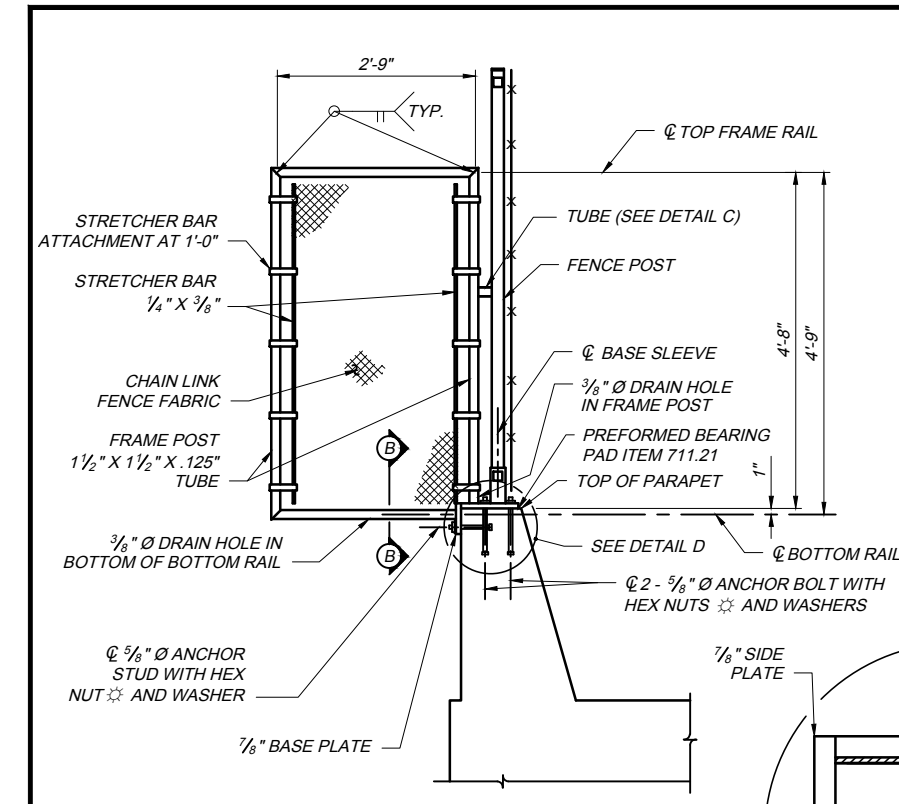

ANTI-CLIMB SHIELD DETAIL
 LOCATE ANTI-CLIMB SHIELD AT POST NEAREST MIDPOINT OF END SPANS. (4 REQUIRED FOR EACH STRUCTURE)
 ✪ STAINLESS STEEL SELF-LOCKING HEX NUT WITH NYLON INSERT
 FOR DETAILS NOT SHOWN, REFER TO (TYPE II CHAIN LINK FENCE DETAIL)

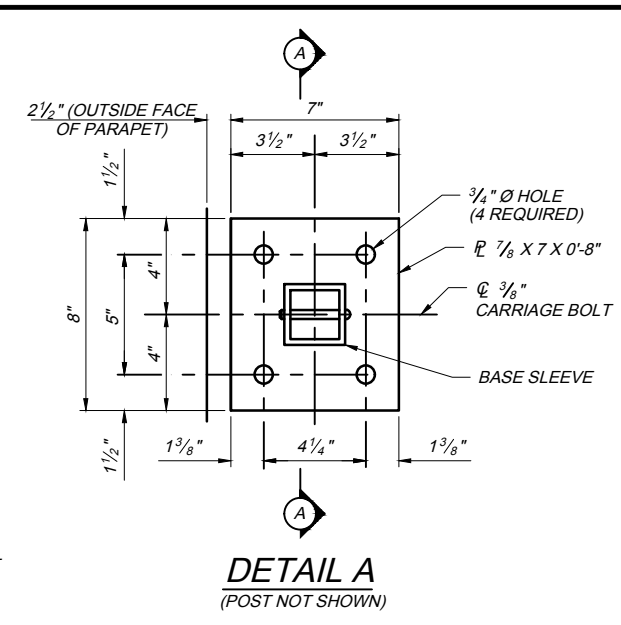

DETAIL A
 (POST NOT SHOWN)

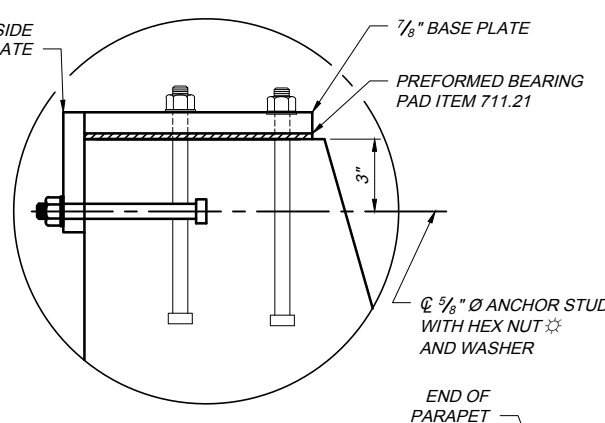

DETAIL D
 (POST NOT SHOWN)

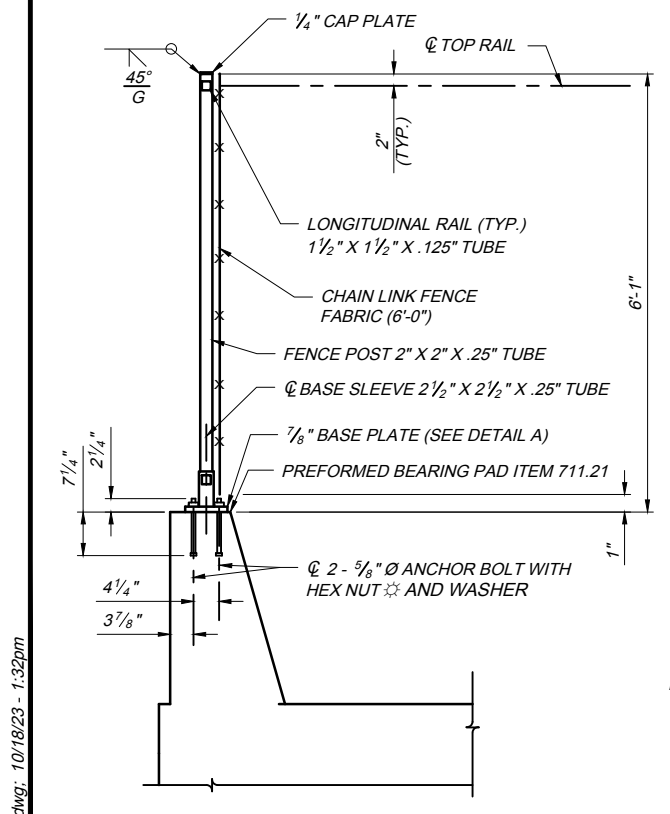

TYPE 2 CHAIN LINK FENCE DETAIL
 ✪ STAINLESS STEEL SELF-LOCKING HEX NUT WITH NYLON INSERT

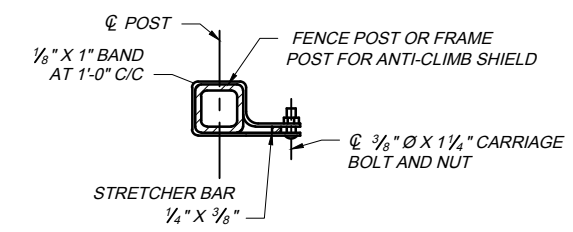

STRETCHER BAR ATTACHMENT

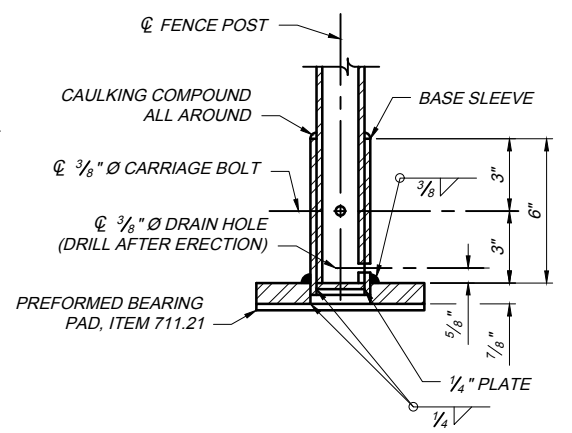

SECTION A-A

NOTE:
 FOR BASE SLEEVE, POST AND RAIL SIZES, SEE FENCE DETAIL.

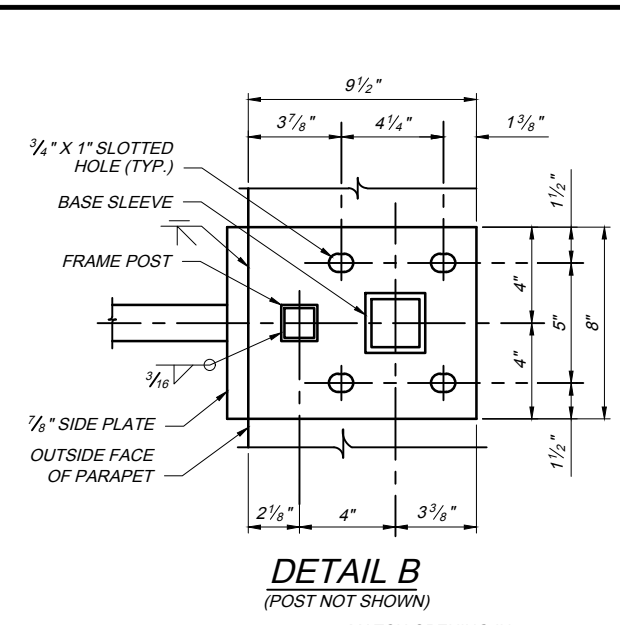

DETAIL B
 (POST NOT SHOWN)

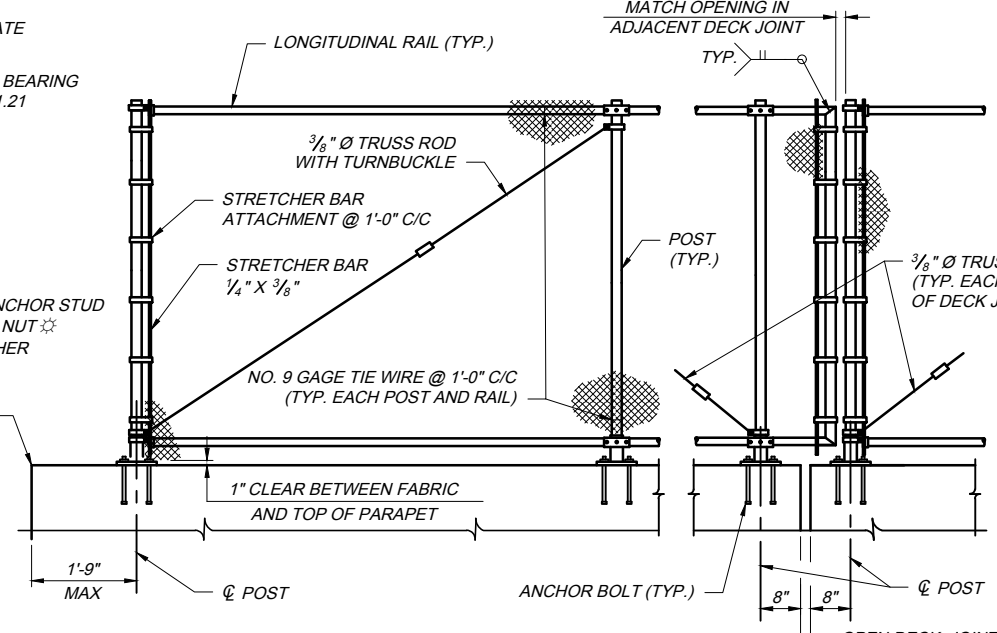

INTERIOR ELEVATION

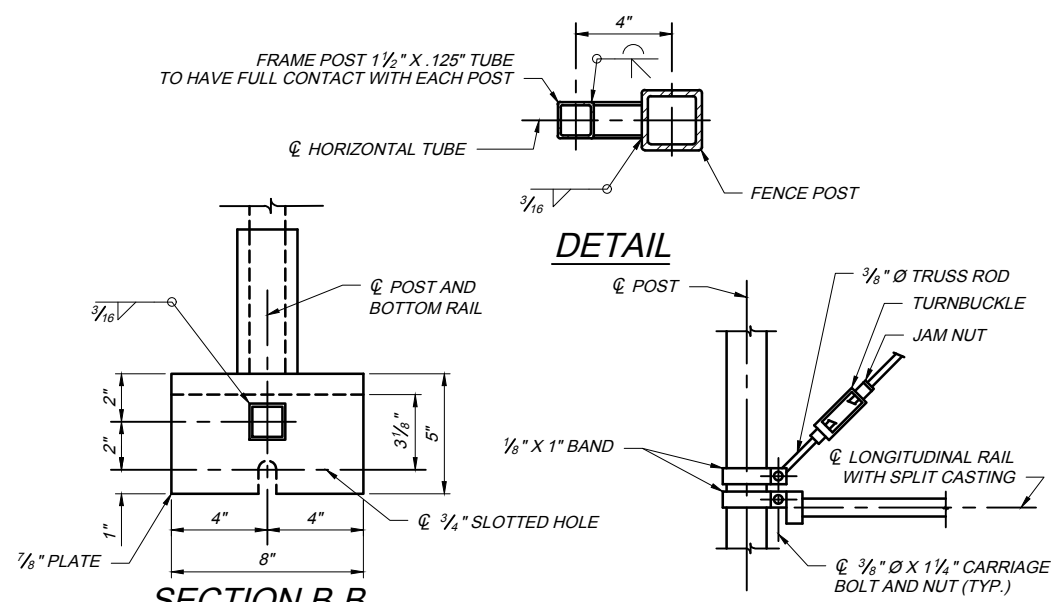

TRUSS ROD AND END PANEL RAIL ATTACHMENT

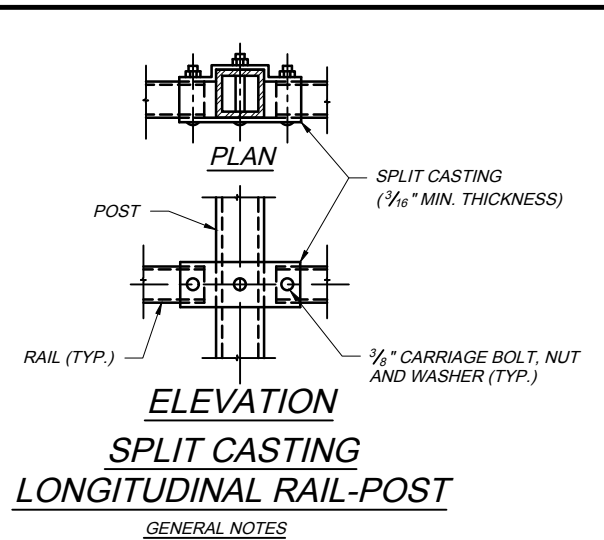

GENERAL NOTES

- SPECIFICATIONS:** JANUARY 2023 EDITION OF OHIO DEPARTMENT OF TRANSPORTATION "CONSTRUCTION AND MATERIAL SPECIFICATIONS"; AASHTO "STANDARD SPECIFICATIONS FOR HIGHWAY BRIDGES, SEVENTEENTH EDITION" AND 2013 EDITION OF AASHTO "STANDARD SPECIFICATIONS FOR STRUCTURAL SUPPORTS FOR HIGHWAY SIGNS, LUMINARIES AND TRAFFIC SIGNALS".
- MATERIALS:** CHAIN LINK FENCE FABRIC SHALL BE 1" MESH WOVEN FROM NO. 9 GAGE ALUMINUM ALLOY WIRE CONFORMING TO THE REQUIREMENTS OF AASHTO M181, TYPE III ASTM F1183 AND SHALL HAVE KNUCKLED SELVAGE AT THE BOTTOM AND AT THE TOP. FABRIC TIES SHALL BE NO. 9 GAGE ALUMINUM ALLOY WIRE CONFORMING TO THE REQUIREMENTS OF ASTM B211, ALLOY 6061, TEMPER T6.

 POSTS, RAILS, PLATES, AND TRUSS RODS SHALL BE ALUMINUM ALLOY CONFORMING TO THE REQUIREMENTS OF ASTM B221, ALLOY 6061, TEMPER T6. SHIMS SHALL BE ALUMINUM ALLOY CONFORMING TO ASTM B209, ALLOY 1100-0.

 RAIL FITTINGS, TURNBUCKLES AND SPLIT CASTINGS SHALL BE ALUMINUM ALLOY CASTINGS CONFORMING TO THE REQUIREMENTS OF ASTM B26, B85 OR B108, ALLOY ZG61A-T5, SG70A-T6, ZC81A-T5, SG100A, SG100B OR S12B.

 CARRIAGE BOLTS AND NUTS SHALL BE ALUMINUM ALLOY CONFORMING TO THE REQUIREMENTS OF ASTM F467 AND F468, ALLOY 2024-T4 FOR BOLTS, AND ALLOY 6061-T6 FOR NUTS. WASHERS SHALL BE ALUMINUM ALLOY CONFORMING TO THE REQUIREMENTS OF ASTM B209, ALLOY 6061-T6. BANDS AND STRETCHER BARS SHALL BE ALUMINUM ALLOY CONFORMING TO THE REQUIREMENTS OF ASTM B221, ALLOY 6063, TEMPER T6.
- ANCHOR STUDS:** MATERIAL FOR ANCHOR STUDS SHALL CONFORM TO ASTM DESIGNATION A-276, TYPE 430 TO TYPE 304 STAINLESS STEEL ANNEALED, HOT-FINISHED, ULTIMATE STRENGTH 70,000 PSI MINIMUM, 20% MINIMUM ELONGATION. THREADS MAY BE ROLLED OR CUT. ANCHOR STUDS SHALL BE SET IN PLACE IN THE FORMWORK UTILIZING A TEMPLATE PRIOR TO THE PLACEMENT OF THE CONCRETE. APPROVAL OF THE ANCHOR STUD PLACEMENT BY THE CHIEF ENGINEER IS REQUIRED PRIOR TO THE PLACEMENT OF THE PARAPET CONCRETE.
- POST SPACING:** FOR POST SPACING, SEE PERTINENT STRUCTURE SHEETS. POST SPACING SHALL BE 8'-0" MAXIMUM.
- ERECTION:** ALL LONGITUDINAL RAILS TO BE PARALLEL TO TOP OF PARAPET. ALL POSTS TO BE SET NORMAL TO TOP OF PARAPET, EXCEPT AS OTHERWISE NOTED IN THE PLANS.
- CERTIFICATION:** THE PRODUCER OR SUPPLIER SHALL FURNISH CERTIFICATES STATING THAT EACH LOT HAS BEEN SAMPLED, TESTED AND INSPECTED IN ACCORDANCE WITH THE SPECIFICATIONS, AND HAS MET THE REQUIREMENTS.
- ALUMINUM SURFACES** TO BE ISOLATED FROM CONTACT WITH CONCRETE WITH 1/8" THICK PREFORMED BEARING PADS, ITEM 711.21 PADS SHALL BE THE SAME SIZE OF PLATE CONTACT SURFACES.
- CAULKING COMPOUND** SHALL CONFORM TO FEDERAL SPECIFICATION TT-S-00230C TYPE II, CLASS A, ALUMINUM GRAY. WHEN APPLYING THE CAULK TO THE BASE PLATE, PROVIDE A 1" OPENING THROUGH THE CAULK ON THE LOW SIDE OF THE BASE PLATE.